



WATER SYSTEMS ECODIVER

 **DAB PUMPS LTD.**
Unit 4, Stortford Hall Industrial
Park Dunmow Road, Bishops Stortford, Herts
CM23 5GZ - UK
info.uk&eire@dwtgroup.com
Tel.: +44 1279 652 776
Fax: +44 1279 657 727

 **DAB PUMPS B.V.**
Albert Einsteinweg, 4
5151 DL Drunen - Nederland
info.netherlands@dwtgroup.com
Tel.: +31 416 387280
Fax: +31 416 387299

 **DAB PUMPS B.V.**
Brusselstraat 150
B-1702 Groot-Bijgaarden - Belgium
info.belgium@dwtgroup.com
Tel.: +32 2 4668353
Fax: +32 2 4669218

 **DAB PUMPEN DEUTSCHLAND GmbH**
Tackweg 11
D - 47918 Tönisvorst - Germany
info.germany@dwtgroup.com
Tel.: +49 2151 82136-0
Fax: +49 2151 82136-36

 **DAB PUMPS INC.**
3226 Benchmark Drive
Ladson, SC 29456 USA
info.usa@dwtgroup.com
Ph. : 1-843-797-5002
Fax : 1-843-797-3366

 **DAB PUMPS IBERICA S.L.**
Parque Empresarial San Fernando
Edificio Italia Planta 1ª
28830 - San Fernando De Henares - Madrid
Spain
info.spain@dwtgroup.com
Ph.: +34 91 6569545
Fax: +34 91 6569676

 **DWT GROUP Russia**
100 bldg. 3 Dmitrovskoe highway,
127247 Moscow - Russia
info.russia@dwtgroup.com
Tel.: +7 495 739 52 50
Fax: +7 495 485-3618

 **DAB PUMPS CHINA**
Shandong Sheng Qingdao Shi
Jinji Jishu Kaifaqu Kaituo Rd
ZIP PC266510
CN - China
info.china@dwtgroup.com
Tel.: +8613608963089
Fax: +8653286812210



ECODIVER

HYDRAULIC DATA

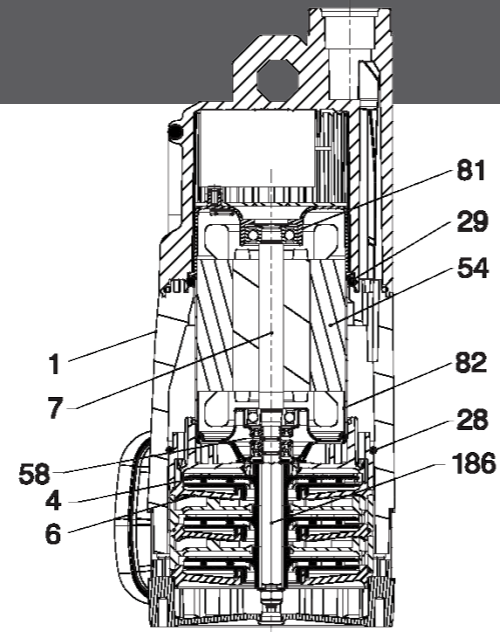

TECHNICAL DATA

CONSTRUCTION

No.	Description	Material
1	Pump Body	PP OMO 30% FVAC
4	Impeller	PPO/PPE 20% FV
6	Diffuser	PPO/PPE 20% FV
7	Rotor Shaft	INOX AISI 416
28	O Ring	NBR 70
29	O Ring	NBR 70
54	Motor Casing	fe P01 0.65mm
58	Ceramic Bush	INOX AISI 416
81	Upper Bearing Support	Cast Aluminum
82	Lower Bearing Support	Cast Aluminum
186	Pump Shaft	Hexagonal AISI 303

TECHNICAL DATA

FEATURES & BENEFITS

- Plug & Play
- Large range to cover various requirements
- Provides Excellent flows "In a compact design"
- Efficient motors
- 115v 60Hz
- CSA and UL approved
- Dry Run protection (with Float Switch)
- Built in thermic overload

APPLICATIONS

Powerfull Multi-stage Submersible Pumps

Available with 2, 3 and 4 impellers. Suitable to pump clear water. Manufactured with anti-corrosive and rust-proof materials. Motor with thermic overload protection. Wear resistant shaft. Anti-debris stainless steel strainer.

The excellent cooling of the motor that enables the pump to operate even when it is partially submerged. An automatic version is available with a start/ stop float switch. Supplied with power cable with plug, non return valve and 4-step fitting.

ideal for

- rain water systems
- operating sprinklers
- pumping water from tanks & cisterns,
- pumping water from ponds and wells
- other applications that require high pressure

TECHNICAL DATA

Model	HP	Watts	Volts	Frequency	Amps	Float Switch	Max Flow	Max Head	Impellers	Max PSI
ECODIVER 750	1/2	750	115	60 Hz	6.8	No	25 gpm	79 ft	2	35
ECODIVER 750-A						Yes				
ECODIVER 1000	3/4	900	115	60 Hz	8.4	No		118 ft	3	52
ECODIVER 1000-A						Yes				
ECODIVER 1200	1	1100	115	60 Hz	9.8	No	157 ft	4	64	
ECODIVER 1200-A						Yes				

TECHNICAL DATA

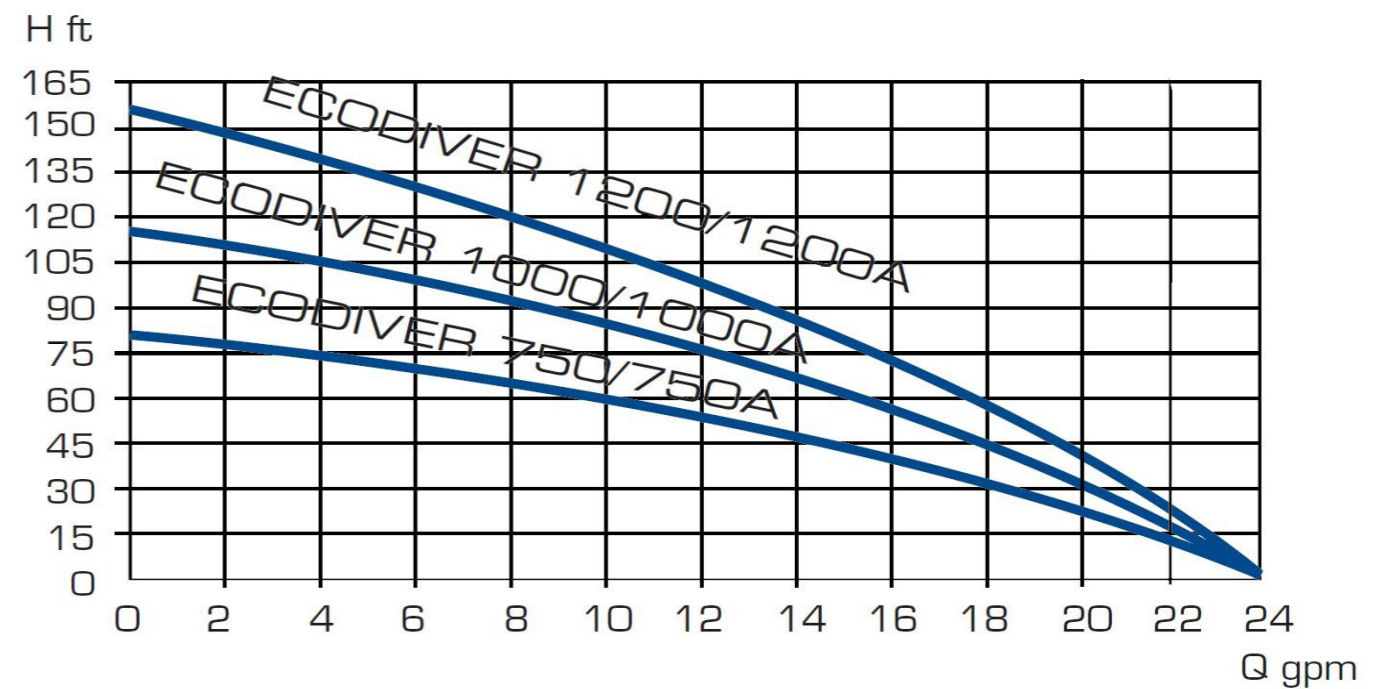

DIMENSIONS

Model	H	H1	A	ØB	Weight	Pallet Qty
ECODIVER 750	13.8"	11.5"	5.9"	1"	16.0 lbs	40
ECODIVER 750-A	13.8"	11.5"	5.9"	1"	16.5 lbs	
ECODIVER 1000	14.8"	12.5"	5.9"	1"	18.7 lbs	
ECODIVER 1000-A	14.8"	12.5"	5.9"	1"	19.1 lbs	
ECODIVER 1200	15.8"	13.5"	5.9"	1"	19.4 lbs	
ECODIVER 1200-A	15.8"	13.5"	5.9"	1"	19.8 lbs	

