

ECOPLUS



GENERAL DATA

Applications

Multi-stage, self priming centrifugal pump with horizontal shaft, with optimal liquid aspiration even in the presence of air bubbles, featuring extremely quiet operation suitable for domestic water supply and pressurization, irrigation of gardens and general water movement.

Constructional features of the pump

Technopolymer pump body and motor support.
Technopolymer impeller, diffuser, self-priming disc.
Carbon/ceramic mechanical seal.

Constructional features of the motor

Induction motor, closed and cooled with external ventilation.
Rotor mounted on oversized greased sealed-for-life ball bearings to ensure silent running and a long life.
Built-in thermal and current overload protection on ECOPLUS230
Built-in thermal and resettable overload protection on ECOPLUS 240/250
Capacitor permanently in circuit.
Manufactured according to UL 778 -2010 & CSA 108-1
Motor protection: NEMA3
Terminal Box protection: NEMA3
Insulation class: F

Standard voltage: 115v 60Hz

TECHNICAL DATA

MATERIALS

N°	PARTS*	MATERIALS
1	SUCTION FLANGE	TECHNOPOLYMER
2	INSERT	NICKLED BRASS
3	NUT	A2 – UNI7474 STAINLESS STEEL
4	WASHER	A2 STAINLESS STEEL
5	OR GASKET	NBR
6	COUNTERFLANGE	TECHNOPOLYMER
7	OR GASKET	NBR
8	DIFFUSER	TECHNOPOLYMER
9	IMPELLER	TECHNOPOLYMER
10	ROTOR SHAFT	AISI 416 STAINLESS STEEL UNI EN 10088-1 X12CrS13
11	WASHER	A2 STAINLESS STEEL
12	SEEGER RING	AISI 316 STAINLESS STEEL
13	MECHANICAL SEAL	SILICON - VITON
14	COUNTERFACE	STEA/NBR
15	BODY	TECHNOPOLYMER
16	INSERT	NICKLED BRASS

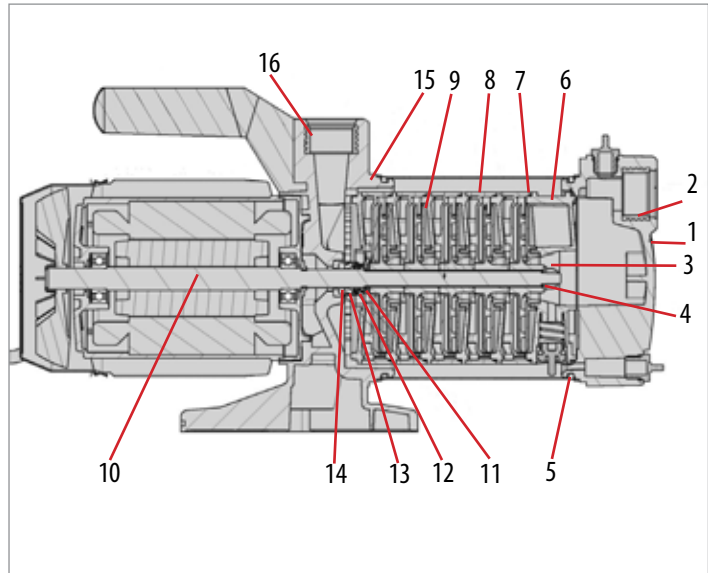

* In contact with liquid

Operating Range:	From 1 to 27gpm with a head up to 197ft (85 psi)
Liquid quality requirements:	clean, free from solids or abrasive substances, non viscous, non aggressive, non crystallized, chemically neutral, close to the characteristics of water
Liquid temperature Range:	From 32°F to 95°F
Maximum Suction depth:	26 ft
Maximum ambient temp.	104°F
Maximum operating pressure	116 psi
Installation:	fixed or portable in a horizontal position
Special version on request	other voltages and/or frequencies

ECOPLUS 230

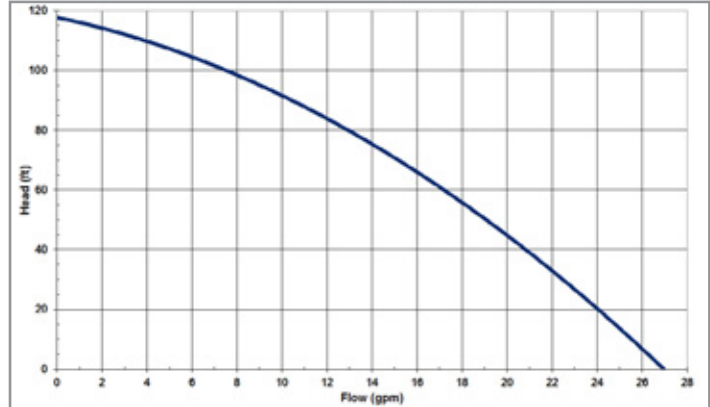
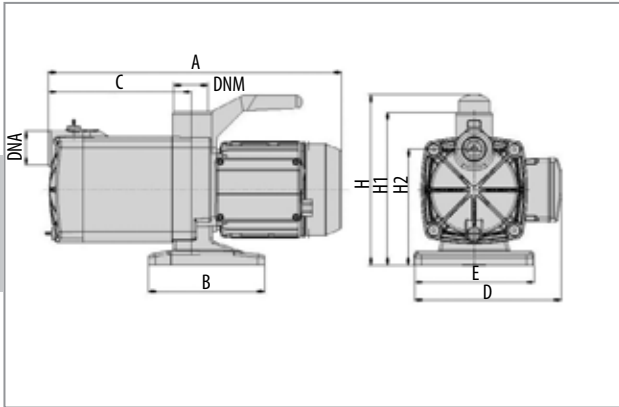

MODEL	A	B	C	D	E	H	H1	H2	DNA	DNM	Weight
ECOPLUS 230	16 1/8"	6 3/4"	7 1/8"	8 1/2"	5 5/8"	9 5/8"	8 3/4"	6 5/8"	1" NPT	1" NPT	19.0 lbs

MODEL	ELECTRICAL DATA				HYDRAULIC DATA		
	Voltage 60Hz	P1 kW Hp		In A	MAX Flow	Max Head	Max Pressure
ECOPLUS 230	115v	800	1/2	8.0	27 gpm	118 ft	51 psi

ECOPLUS 240

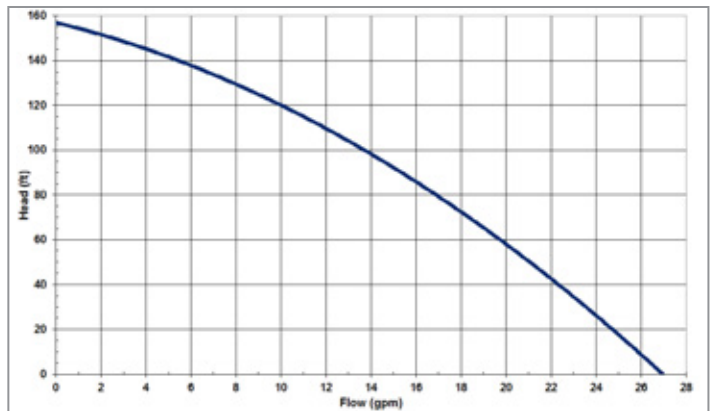
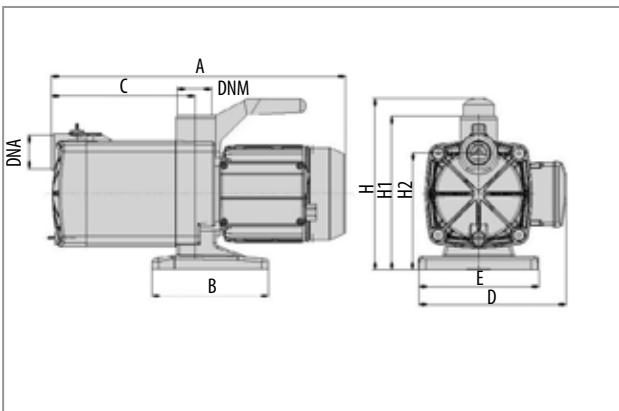

MODEL	A	B	C	D	E	H	H1	H2	DNA	DNM	Weight
ECOPLUS 240	17"	6 3/4"	8 1/4"	8 1/2"	5 5/8"	9 5/8"	8 3/4"	6 5/8"	1" NPT	1" NPT	26.0 lbs

MODEL	ELECTRICAL DATA				HYDRAULIC DATA		
	Voltage 60Hz	P1 kW Hp		In A	MAX Flow	Max Head	Max Pressure
ECOPLUS 240	115v	1000	3/4	10.0	27 gpm	157 ft	68 psi

ECOPLUS 250

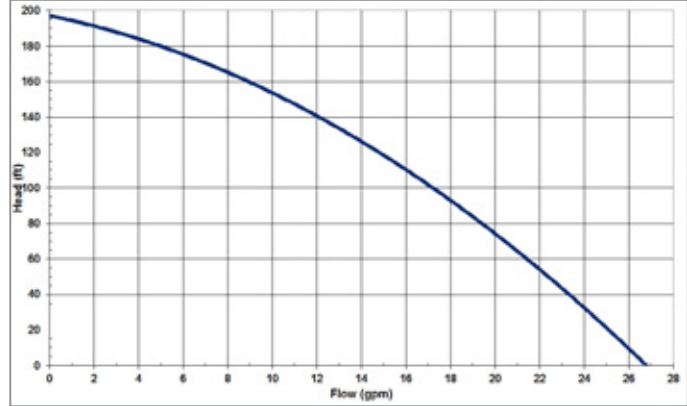
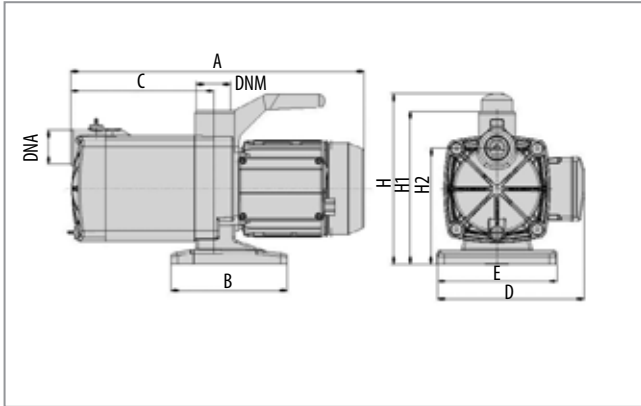

MODEL	A	B	C	D	E	H	H1	H2	DNA	DNM	Weight
ECOPLUS 250	18"	6 3/4"	9 1/4"	8 1/2"	5 5/8"	9 5/8"	8 3/4"	6 5/8"	1" NPT	1" NPT	27.4 lbs

MODEL	ELECTRICAL DATA				HYDRAULIC DATA		
	Voltage 60Hz	P1		In A	MAX Flow	Max Head	Max Pressure
		kW	Hp				
ECOPLUS 250	115v	1250	1	13.0	27 gpm	197 ft	85 psi