

TR6-TR8-TR10-TR12-TR14

Contents:

0.	Foreword, Warranties and Limitations	3
1.	General Description	
1.1	Motor	4
1.2	Construction features	4
1.3	Applications	4
2.	Transport and Storage	
2.1	Transport	5
2.2	Storage	
3.	General Safety Instructions	
3.1	General Safety Instructions	5
4.	Installation	
4.1	Motor fill-up	6
4.2	Insulation checking	6
4.3	Electrical connections	6
4.4	Electrical equipment	6
4.5	Electrical protections	7
4.6	Rotation direction	7
4.7	Further instructions for six-cables motors terminal connections	7
4.8	Operation	7
5.	Motor checking and fault finding	
5.6	Supply voltage	8
5.7	Energy absorption	8
5.8	Windings resistance	8
5.9	Insulation resistance	8
6.	Maintenance and reparation	
6.1	Dismantling the motor	9
6.2	Assembling the motor	9
6.3	Motor testing	9
7.	Spare parts	
7.1	Ordering Procedures	9
8.	Decommissioning and dismantlement	
8.1	Dismantlement	9

0. FOREWORD, WARRANTIES AND LIMITATIONS

Foreword

The purpose of this instructions manual is to ease as much as possible the installation

We strongly recommend to read it attentively and to consult it whenever work is done on the motor. Unobservance of the instructions here reported or improper use of the motor by unskilled personnel may compromise motor life and proper operation.

technical assistance is readily available: for any doubt or possible problem, please contact us also by phone.

The motors are carefully inspected and tested before dispatchment. Check however the equipment at delivery against the accompanying documents. Check box integrity before removing the motor. Parts and accessories can be packed alone or fastened to the box. If something is missing or damaged, please contact immediately Your local forwarding agent.

Warranty and Limitations

The warranty does not include possible damages or failure caused by mishandling, wrong electrical connections and uncorrect assembling.

The warranty also excludes in all cases the issuing of pass certificates and remboursements for the equipment or for consequential damage.

We decline any responsibility for damages to persons and things due to improper use of the machinery here described.

Normal wear parts are not subjected to warranty.

Safety warning

The following symbols will be used on this instruction manual to highlight instructions whose unobservance may imply a potential danger to people and things:



A) DANGER

Warns against the risk of electric shock implied. Risk of electric shock in the unobservance of the relevant instruction.



B) DANGER

Warns against the risk of personal injury or extensive damage implied in the unobservance of the relevant instruction.



C) WARNING

Warns against the risk of damage to the motor and/or the installation implied in the unobservance of the relevant instruction.

Beware: Read thoroughly this instruction manual before installing the motor. The warranty will not apply to any damage caused by unobservance of the instructions here reported. Motor installation, operation and servicing must be performed by qualified personnel only.

1. PRODUCT DESCRIPTION

1.1 Motor

Winding: Wire of pure electrolytic copper sheated with special non-Hydroscopic thermoplastic material of high dielectric strenght characteristics.

Stator: casing in stainless steel

Rotor: Squirrel cage. Rotor is dynamically balanced for smooth and vibration-free operation.

Thrust bearing: Self equalizing and sel-aligning Michell or Kingsbury type assembly, water lubricated.

Shaft bearing: Anti-wear bush bearing in metallized graphite. Water lubrication provides minimum friction and complete compatibility with well water.

Shaft: Stainless steel shaft of oversized design minimized deflection, lengthening service life.

Seal: rubber lip-type shaft seal or mechanical seal.

Diaphragm: equilizing diaphragm compensates for submergence pressure.

Motor: is filled with water.

Cable: rubber single-core or triple-core, depending on the of motor.

1.2 Construction features

Our submersible motors are designed and tested according to IEC 34 Standards. Motor nameplate shows the following operating data:

- Manufacturer
- Motor type
- Part Number
- Production date
- Voltage (V)
- Ampere (A)
- Power (kW)
- Reference standard IEC 34
- Frequency (Hz)
- Rotational velocity (rpm)
- Power factor (cos φ)
- CE marking
- Weight
- Operating condition

TR12		No.	60120726		Model A	SN	PCP8 0930	
Phase	Voltage	Frequency	P2	P3	SI	Max.SI C.	cos φ	n
[L]	[V]	[Hz]	[kW]	[hp]	[L]	[kg]	[L]	[rpm-1]
3	380	50	250	340	1,00	502,0	0,853	2942
3	400	50	250	340	1,00	516,0	0,792	2942
3	415	50	250	340	1,00	539,0	0,73	2951

liquid max. 25 °C at 0,5 m/s - 55 °C at 1,5 m/s
 Duty S1
 Connection Y/D
 Weight 775 kg/ 1709 lb
 IP58
 MADE IN ITALY
 V71237-11

CE IEC 34

 submersible motors

1.3 Applications

Submersible motors are coupled to submersible pumps and installed in a vertical position for use in the following applications:

- Industrial and civil applications
- Irrigation systems
- Water supply systems
- Mining
- Offshore
- Nuclear and steam power stations
- Fire-fighting equipments

2. TRANSPORT AND STORAGE

2.1 Transport



Before transportation, please checks:

- Motor weight
- Motor overall dimensions
- Suitability of lifting points.

The submersible motors and their accessories (if included) are packed in boxes suited for transportation to avoid any damage on the way. However, we recommend to inspect carefully the motor at delivery.

The motor should be handled with equipment suited to its weight and to the shape of its crate (see Figure 1) to avoid possible damages due to mishandling. Lifting by hand is allowed only for weights lower than 20 kilograms. For higher weights, we suggest to lift the motor as shown in Figures 2 and 3.

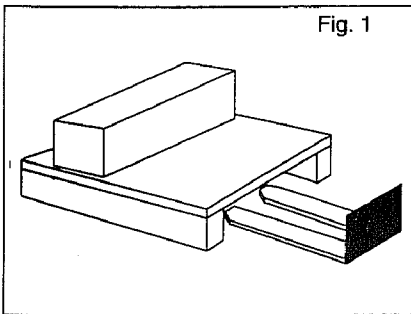

Fig. 1

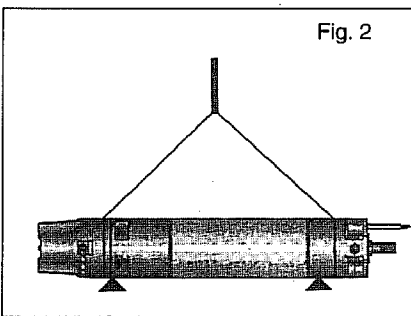

Fig. 2

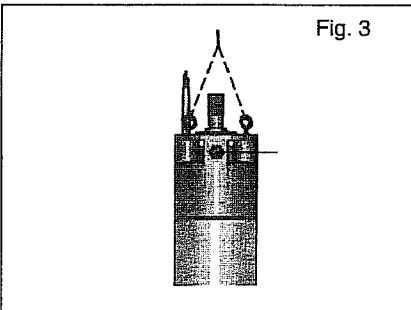

Fig. 3

2.2 Storage



During storage, please observe the following precautions:

- Store the motor in a closed, dry and airy environment.
- All motors are filled with a water-antifreeze mixture to prevent internal freezing below -10°C .
- Motors should not be stored or installed with lower temperatures or for periods longer than 12 months; however, if this is unavoidable turn the shaft by hand once a month.
- Motors stored for more than 12 months must be checked by an authorized shop before installation.
- Protect cable ends against humidity.
- To avoid any damage to the electric cables, never bend them with a curving radius lower than 6 times their diameter.
- Protect against direct sunlight the electric cables and, in case the motor will be stored partially dismantled, the rubber parts and the thrust bearings.

3. GENERAL SAFETY INSTRUCTIONS

3.1 General Instructions

- Make sure that voltage and frequency reported on motor nameplate correspond to mains voltage and frequency.
- Electrical connections should be made only by specialized personnel strictly following accident prevention rules, the electric patterns shown on this manual and the control panel electric patterns. Grounding cables (green and yellow cables) must be connected to the plant grounding circuit. Make sure the control panel conforms to current standards and has a protection degree suited to the installation site.
- The motor should be used only for the applications and within the limits specified in point 1.3. In case of applications not specified in this instruction manual, please contact to check for motor suitability.
- Before working on the motor, make sure the electric components of the concerned installation are disconnected from the electric mains.

4. INSTALLATION

4.1 Motor filling

Before proceeding with motor installation, it is necessary to fill up the motor. The motor is delivered filled up with a special mixture assuring bearings lubrication and cooling.

How to fill the motor with liquid:

Before you install the motor, fill the motor with liquid. Follow this procedure:

- Place the motor at a 45° angle with the top of the motor upwards.
- Unscrew the plug A and place a funnel in the hole.
- Pour tap water into the motor until the motor liquid inside the motor begins to flow out the motor at A.
- Remove the funnel and refit the plug A.

Attention:

Before you fit the motor to a pump after a long period of storage, lubricate the shaft seal by adding a few drops of water and turning the shaft.

Note: Motor liquid contains glycerol.

For proper motor operation, never neglect to perform motor filling.

4.2 Insulation checking

Check motor insulation before coupling the motor to the pump. Join one megahometer end to motor case and the other end to the cables coming out of the motor. The megahometer reading should not be lower than 30 megahoms.

4.3 Electrical connection

Electrical connection must be performed by specialized personnel only, strictly following the instructions of motor and electrical equipment manufacturers. If the motor is supplied without cable, the cable must be selected following the prescriptions of Technical Service.

For supply cable selection it is necessary to consider the following factors:

- Mains voltage
- Allowable voltage drop along the line
- Motor BHP
- Cable max. output (Ampere)
- Ambient temperature

Motor cable connection should be performed with extreme care. If two cables have to be connected in parallel, pay extreme attention to join together cables of the same colours or showing the same symbols.

We suggest to leave 2 or 3 meters of cable more in case terminal connections should be changed.

4.4 Electrical equipment

The motor is connected by the supply cable to the control panel, which contains the necessary control and protection devices.

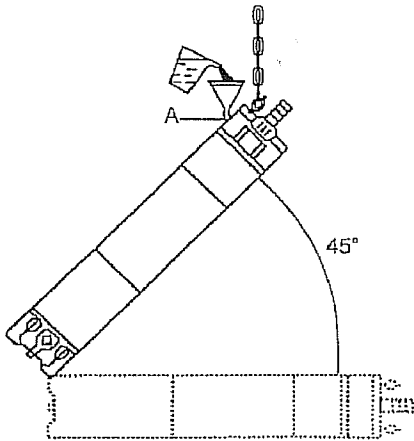

4.2 Insulation checking

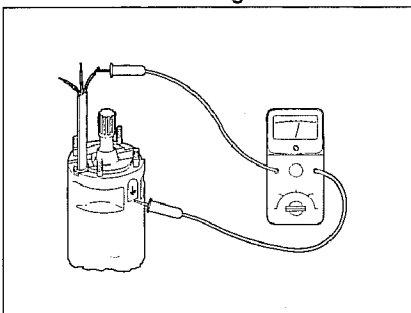

4.3 Electrical connection

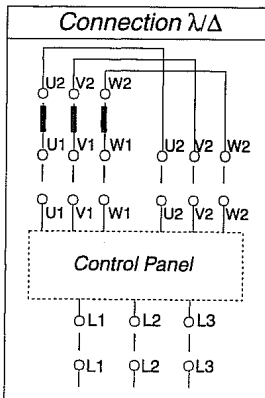
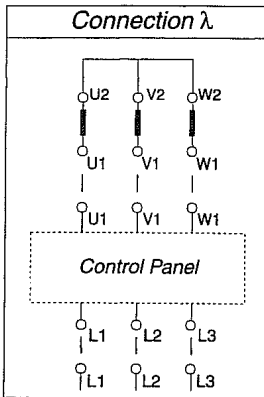
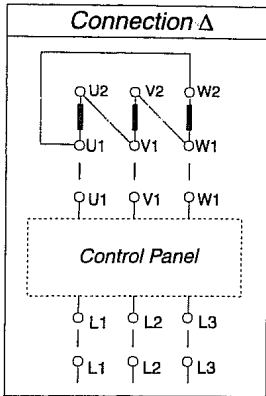

4.6 Rotation direction



Direction of rotation facing delivery side: CCW



Direction of rotation facing delivery side: CW

4.5 Electrical protections



The following protections are always necessary:

- Overload protection
- Short-circuit protection
- Phase drop
- Voltage drop

These protections must trip on all three-phases. We suggest besides to install protections against

- Overload protection
- Short-circuit protection
- Phase drop
- Voltage drop

If the overload thermal protection relay has to be set, remember that with cold motor the protection operating time should be less than 10 sec. with 5 times the motor rated voltage. Therefore, for an optimal result, set the thermal relay as follows:

- Set the thermal relay at motor rated voltage.
- Start the motor and keep it working for half an hour in normal operating conditions.
- Slowly lower thermal setting until tripping the protection.
- Raise tripping value by 5%

For Star/Delta starters with stator impedences and with autotransformers, we suggest a protection operating period lower than 5 - 7 sec.

4.6 Rotation direction

Check motor rotation direction before coupling the motor to the pump, so to avoid any damage to motor thrust bearing. Find and mark by means of a cyclic phase indicator, whose pointer is turning counterclockwise mains terminals L1, L2 and L3 and connect them to control panel terminals L1, L2 and L3.

Star/delta starting

Motor cables are marked with letters U1-V1-W1 e U2-V2-W2. They have to be connected to control panel terminals, respectively: U1-V1-W1 and U2-V2-W2 for counterclockwise rotation (seen from motor/pump coupling).

In case of clockwise rotation, reverse terminals U1-V1 and U2- W2.

DOL, stator and autotransformer starting

Motor cables are marked with letters U1, V1, W1 and have to be connected to control panel terminals, respectively: U1, V1, W1 for clockwise rotation (seen from motor/pump coupling). For clockwise rotation, reverse two of the cables.

4.7 Further instructions for six-cables motors terminals connection

Six cables motors can be started with a Star/Delta starter only if main voltage is at least equivalent to the motor minimum rated voltage. To obtain the correct rotation direction, find main terminals L1, L2 and L3 as previously described.

4.8 Operation



The max. number of startups/hour depends from starter type and motor power.

Up to 75 kW:	10 startups/h
From 75kW to 150kW:	8 startups/h
Over 150 kW:	5 startups/h

All motors can bear a supply voltage deviation of +/- 5% and a frequency deviation of + 6% - 10% from nameplate values.

5. MOTOR CHECKING AND FAULT FINDING

In case of motor checking or malfunctioning during motor operation, operate as follows:

5.1 Supply voltage

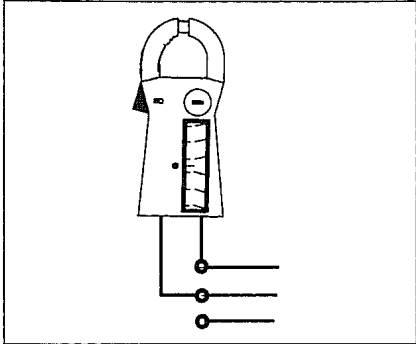

5.1 Supply voltage

Operation:
Check voltage between the phases with a voltmeter

Checking

Running motor voltage has to be as reported at point 4.8. Higher variations might damage motor windings: in this case, stop the motor and check supply voltage.

5.2 Voltage absorption

5.2 Voltage absorption

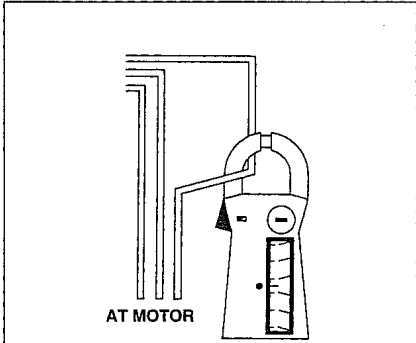

Operation

Measure voltage on each phase. Max. voltage value is reported on motor nameplate

Checking

Voltage difference between the phases should not exceed 5%. Excessive BHP can take place in the following cases:

- Weakening connections in the joinings (see 5.3)
- Supply voltage too low or too high (see 5.1)
- Short-circuiting motor windings (see 5.3 and 5.4)
- Damaged pump overloading the motor
- Resistance value between the phases are too different (see 5.3 and 5.4)
- Asymmetrical supply voltage

5.3 Windings resistance

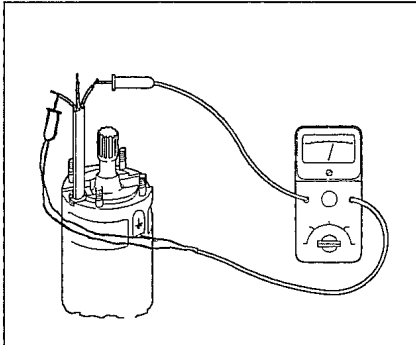

5.3 Windings resistance

Operation

Disconnect output cable from control panel
Measure resistance to leads.

Checking

The difference between resistance values should not exceed 5%. For higher differences, check separately motor and cable and replace defective parts.

5.4 Insulation resistance

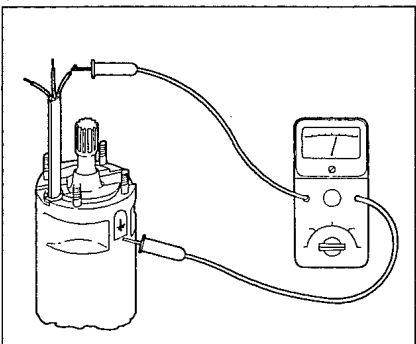

5.4 Insulation resistance

Operation

Disconnect output cable correct from control panel.
Measure insulation between each phase and ground

Checking

Make sure grounding connection is and in good conditions. Insulation with cold motor should be at least 30 megahoms or higher. If this is not the case, check separately motor and cable and replace defective parts.

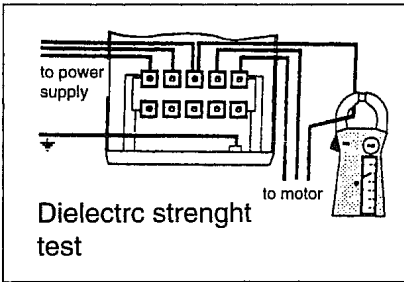
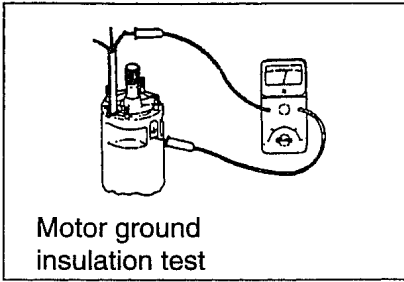

6. MAINTENANCE AND REPAIRATION

6.1 Disassembling the motor

Thanks to its construction features, the motor can be disassembled and reassembled quite easily by using standard shop metric tools. Motor disassembling, reassembling and repairation must be carried out by qualified personnel only or by an authorized shop.

6.2 Reassembling the motor

Once reassembled, the motor cannot operate without being completely filled up as explained in point 4.1.

Before starting, test the motor as explained in 5.3 and 5.4.

6.3 Testing

In case of motor windings replacement, perform the following operation before coupling the motor to the pump.

- Check motor ground insulation by joining one megahometer end to motor case and the other end to the cables coming out of the motor. The megahometer reading should not be lower than 30 megahoms.
- Connect motor to the mains through motor control panel and give a voltage pulse at voltage rated value. Check phase absorption for each phase: the values should be even, with a max. allowable difference of +/- 5%. Detected voltage value should be between 30% and 40% of I_n .
- Dielectric strength test
Place the motor on an insulating support and apply with a suited equipment a $1000V + 2V_n$ voltage for 30 seconds. Once performed the voltage test, check insulation to the ground as explained in 5.4.

7. SPARE PARTS

7.1 Spare parts ordering

For a faster processing of Your order, when ordering spare parts please specify:

- Motor type.
- Motor serial number
- Part name and number as listed on sectional drawings.

The first two informations are easily found on motor nameplate.

8. DECOMMISSIONING AND DISMANTLEMENT

8.1 Dismantlement

When the motor will be permanently stopped and dismantled, the various construction materials should be properly disposed of. It is important to make sure that no residual polluting liquids are trapped within the motor..

The materials used for motor construction are:

- Steel and cast iron
- Aluminium.
- Rubber and plastic.
- Copper

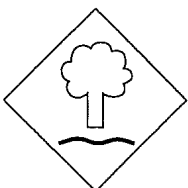

The disposal of polluting liquids and materials should follow current environmental rules.

DAB PUMPS LTD.

Units 4 & 5, Stortford Hall Industrial Park,
Dunmow Road, Bishop's Stortford, Herts
CM23 5GZ - UK
salesuk@dwtgroup.com
Tel.: +44 1279 652 776
Fax: +44 1279 657 727

DAB PUMPS B.V.

Brusselstraat 150
B-1702 Groot-Bijgaarden - Belgium
info.belgium@dwtgroup.com
Tel.: +32 2 4668353
Fax: +32 2 4669218

PUMPS AMERICA, INC. DAB PUMPS DIVISION

3226 Benchmark Drive
Ladson, SC 29456 USA
info.usa@dwtgroup.com
Ph. : 1-843-824-6332
Toll Free: 1-866-896-4DAB (4322)
Fax : 1-843-797-3366

OOO DWT GROUP

100 bldg. 3 Dmitrovskoe highway,
127247 Moscow - Russia
info.russia@dwtgroup.com
Tel.: +7 495 739 52 50
Fax: +7 495 485-3618

DAB PUMPS POLAND SP. n"t.c."

Mokotow Marynarska
ul. Postępu 15C
02-676 Warszawa - POLAND
Tel. +48 223 81 6085

DAB PUMPS CHINA

No.40 Kaituo Road, Qingdao Economic &
Technological Development Zone
Qingdao City, Shandong Province, China
PC: 266500
info.china@dwtgroup.com
Tel.: +8653286812030-6270
Fax: +8653286812210

DAB PUMPS IBERICA S.L.

Avenida de Castilla nr.1 Local 14
28830 - San Fernando De Henares - Madrid
Spain
info.spain@dwtgroup.com
Ph.: +34 91 6569545
Fax: +34 91 6569676

DAB PUMPS B.V.

Albert Einsteinweg, 4
5151 DL Drunen - Nederland
info.netherlands@dwtgroup.com
Tel.: +31 416 387280
Fax: +31 416 387299

DWT South Africa

Podium at Menlyn, 3rd Floor, Unit 3001b,
43 Ingersol Road, C/O Lois and Atterbury,
Menlyn, Pretoria, 0181 South-Africa
info.sa@dwtgroup.com
Tel +27 12 361 3997
Fax +27 12 361 3137

DAB PUMPEN DEUTSCHLAND GmbH

Tackweg 11
D - 47918 Tönisvorst - Germany
info.germany@dwtgroup.com
Tel.: +49 2151 82136-0
Fax: +49 2151 82136-36

DAB UKRAINE Representative Office

Regus Horizon Park
4M. Hrinchenka St, suit 147
03680 Kiev. UKRAINE
Tel. +38 044 391 59 43

DAB PRODUCTION HUNGARY KFT.

H-8800
NAGYKANIZSA, Buda Ernó u.5
HUNGARY
Tel. +36.93501700

**DAB PUMPS S.p.A.**

Via M. Polo, 14 - 35035 Mestrino (PD) - Italy
Tel. +39 049 5125000 - Fax +39 049 5125950
www.dabpumps.com

05/15 cod.60124127