

TR 8 100HP 2Pole
460v 60Hz
Data Sheet

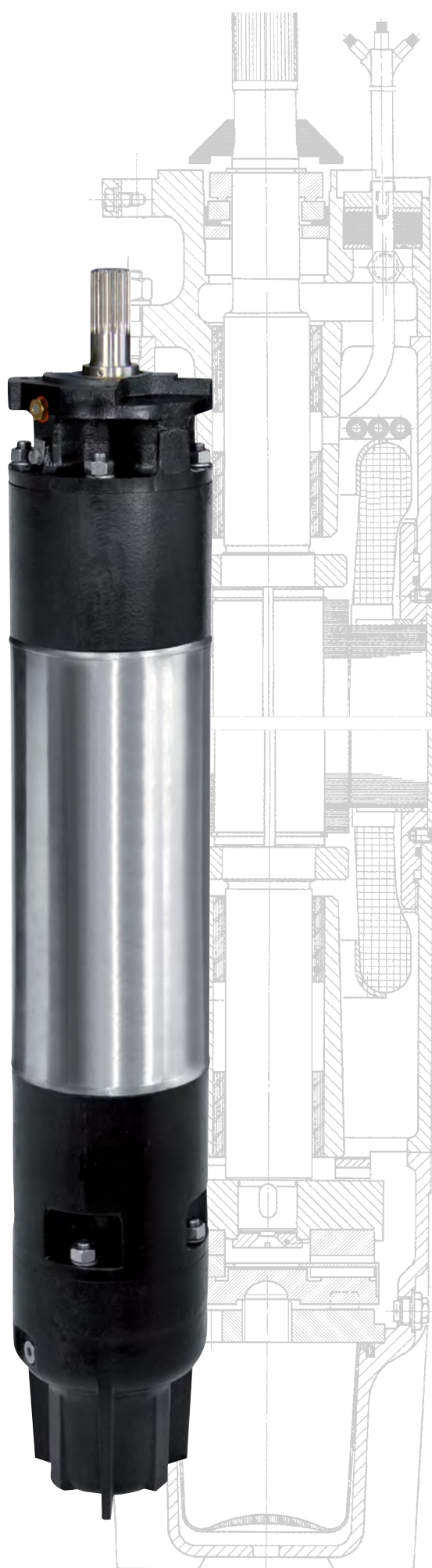

8" Asynchronous two-pole submersible motor, rewindable type, with an external shell made in AISI 316 stainless steel and supports in cast iron with paint coating (standard version). Cooling and lubrication of the thrust bearing assembly and carbon bushes is provided by a mixture of water and glycol. Squirrel-cage rotor mounted on Mitchell self-centring thrust bearing. The motor is available also in full stainless steel AISI 316 version or AISI 904 version. The USA version suitable for use with variable frequency drive (30 Hz-60 Hz). The motor is equipped with 16 feet single-core cables directly connected with the windings and it's available with DOL or STAR-DELTA starting type. The cables are certified ACS and WRAS and KTW. Overload protection must be provided by user. On request PT100 and PTC temperature sensors are available.

| TECHNICAL SPECIFICATION | |
|-------------------------|------------------------|
| Flange | NEMA 8" |
| Degree of protection | IP58 - (IP68) optional |
| Cooling flow | 0.5 m/s (1.64 ft/sec) |
| Voltage tolerance | + 6% / -10% |
| Max starts | 10/h |
| Max operating depth | 300 m (984 ft) |
| Max operating pressure | 60 bar (870 psi) |
| Horizontal operation | 30 Hp - 125 Hp |

| COMPONENTES | |
|--|--|
| The stator is rewindable type and it's inserted in an AISI 316 stainless steel outer shell (on request AISI 904). In the USA version the windings are made in copper PE2+PA windings for special applications such as the use with a variable frequency drive. | |
| Mitchell type thrust bearing unit consisting of tilting pads in graphite and ceramic disc. From 30 HP to 150 HP: 60000 N (13500lbf) Upthrust: 12500 N (2850 lbf) | |
| Shafts made of stainless steel with end part with key coupling. Squirrel-cage rotor made in copper. In the USA version the motor is equipped with a silicon carbide (SiC/SiC) mechanical seal. On request the motor can be equipped also with a lip seal (granting the IP 68 insulation).. | |

DERATING - DECLASSAMENTO - DECLASSIFICACION

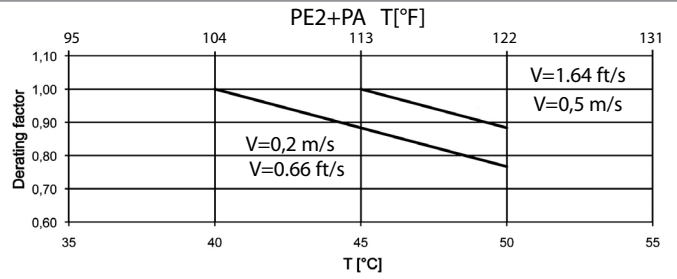
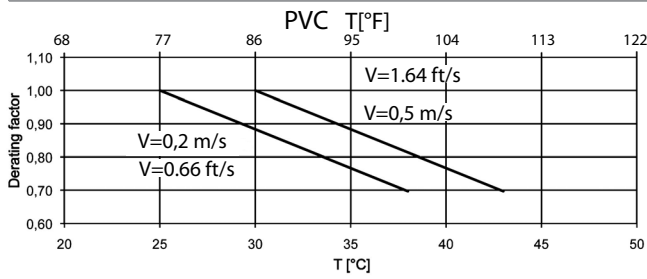

For TR8 150 (110 kW) the maximum liquid temperature is 5 °C (9 °F) lower than the values stated in the table above.

ELECTRICAL DATA 60 Hz

THREE PHASE MOTORS

DOL

2 POLE

| P2 | V* | In | Is/In | P1 | N | Cos j | h | Ø | LC |
|------|------|-----|-------|-------|----------------------|-------|----|---------|------|
| [hp] | [kW] | [V] | [A] | [W] | [min ⁻¹] | | % | [AWG] | [ft] |
| 100 | 75 | 460 | 143 | 99138 | 3500 | 0.86 | 87 | 3x4+1x4 | 16 |

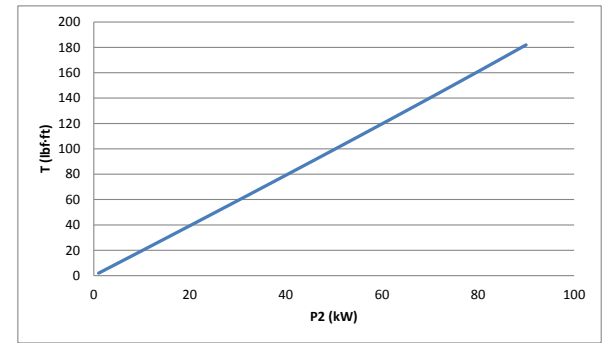
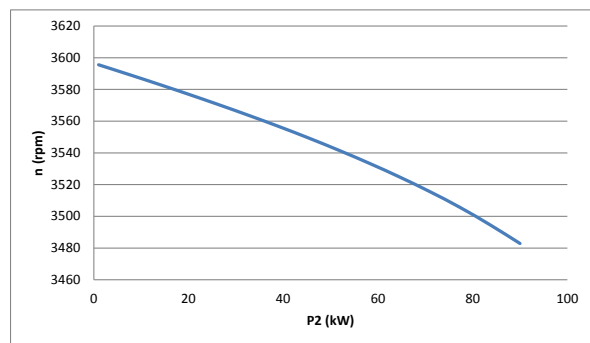
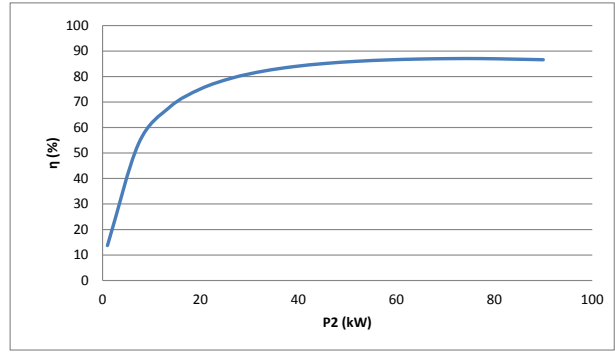
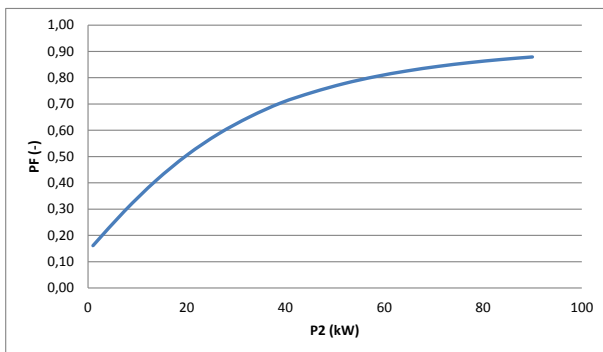
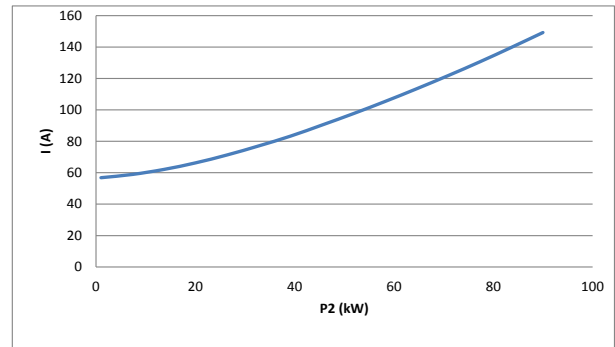
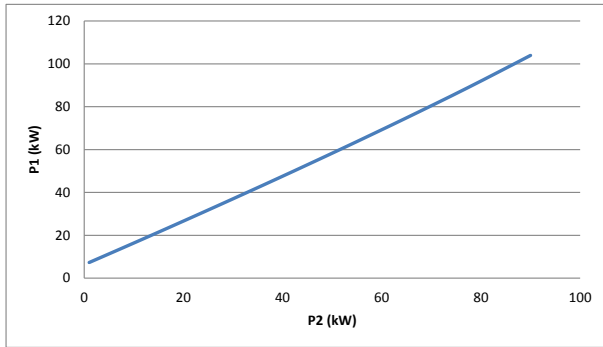

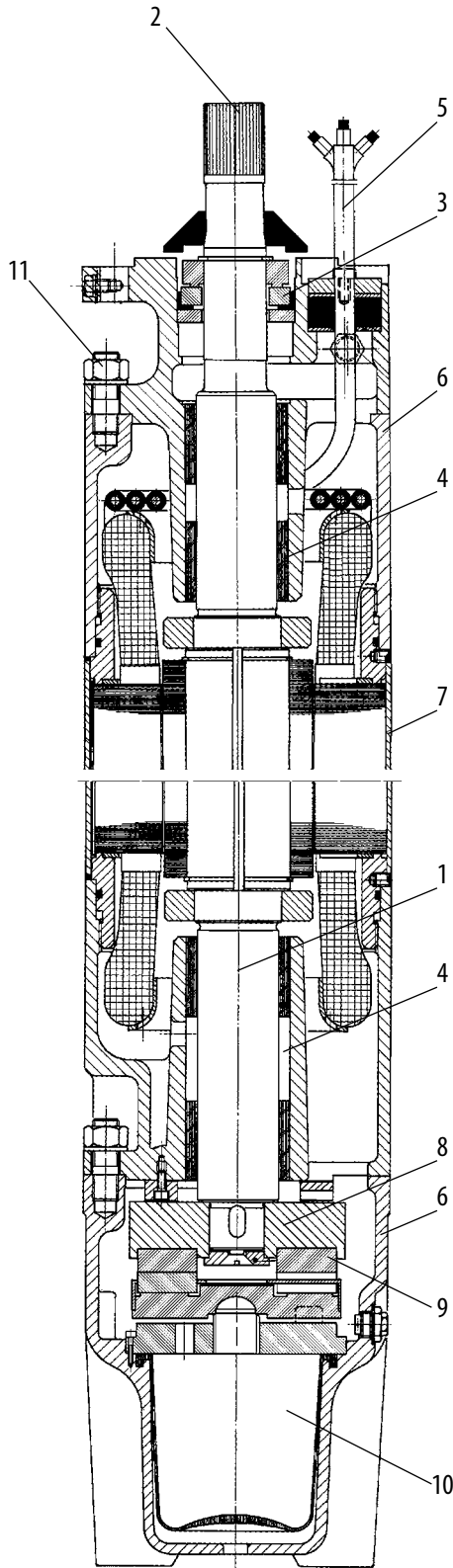

MATERIALS - MATERIALI - MATERIALES

| COMPONENTS | STD version | 316 SS version | 904 SS version |
|-----------------------------|--------------------------|--------------------------|--------------------------|
| 1 Shaft | Stainless steel | Stainless steel | Stainless steel |
| 2 Shaft end | Stainless steel AISI 316 | Stainless steel AISI 316 | Stainless steel AISI 904 |
| 3 Mechanical seal | Ceramic / Carbon | Sic/Sic | SiC / SiC |
| 4 Bearing ring | Graphite | Graphite | Graphite |
| 5 Cable | EPDM | EPDM | EPDM |
| 6 Structural parts | Cast Iron | Stainless steel AISI 316 | Stainless steel AISI 904 |
| 7 External sleeve | Stainless steel AISI 316 | Stainless steel AISI 316 | Stainless steel AISI 904 |
| 8 Thrust bearing rotating | Ceramic | Ceramic | Ceramic |
| 9 Thrust bearing stationary | Graphite | Graphite | Graphite |
| 10 Diaphragm | EPDM | EPDM | EPDM |
| 11 Bolts & screws | Stainless steel AISI 304 | Stainless steel AISI 316 | Stainless steel AISI 904 |

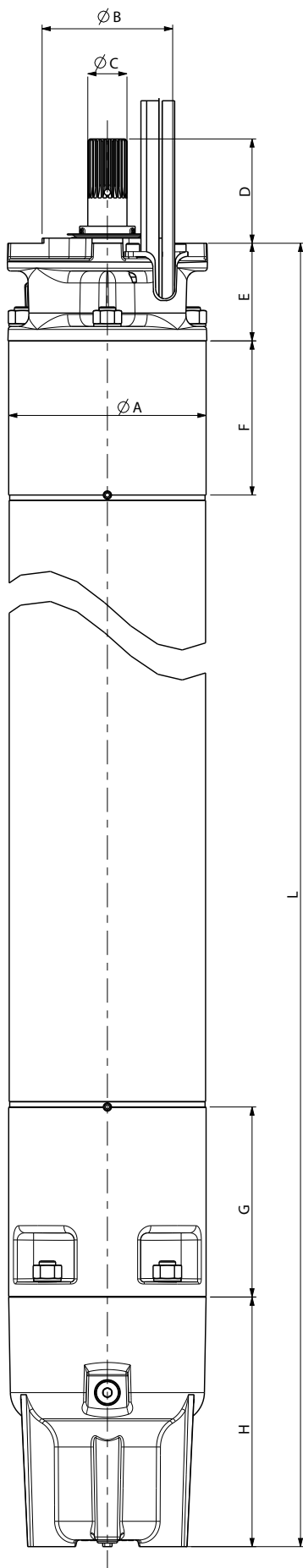

DIMENSIONS - DIMENSIONI - DIMENSIONES

THREE PHASE MOTORS - MOTORI TRIFASE - MOTORES TRIFASICOS

2POLES - 2 POLI - 2 POLOS

| Type | P2 | | L [mm] | L [inch] | Weight | | Axial thrust [lbf] |
|------|------|------|-----------|-------------|--------|-------|-----------------------|
| | [hp] | [kW] | | | [Kg] | [lbs] | |
| 60Hz | 100 | 75 | 1590 | 63 | 237 | 522 | 13500 |

DIMENSIONS - DIMENSIONI - DIMENSIONES

| Pos. | mm | inch | Pos. | mm | inch |
|------|--------|-------|------|----------|------------|
| A | Ø 192 | 7.559 | G | 185 | 7.283 |
| B | Ø 127 | 5" | H | 243 | 9.567 |
| C | Ø 38.1 | 1 ½" | I | 4 x Ø 18 | 4 x 0.709" |
| D | 101.6 | 4" | J | 68 | 2.677 |
| E | 95 | 3.740 | K | Ø 152.5 | 6.004 |
| F | 150 | 5.906 | | | |

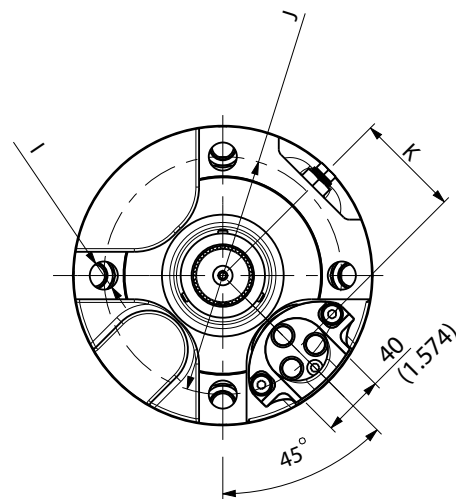

TR8
US VERSION