

FEKA BVP

SEWAGE PUMPS



Powerful submersible pumps for drainage and emptying duty. Designed for pumping sewage water containing solid particles of no more than 1.5 in in diameter. Anti-corrosion and anti-oxidation materials. Motor with THERMALPROTECTION against overheating. Wear-resistant motor shaft and impeller. Excellent motor cooling to allow pump to run even when only partially submerged. Automatic version equipped with float switch for automatic STARTING and stopping of the pump, and Manual version. Equipped with power cable with plug, and 3-level union, without check valve. In compliance with CSA Standards C22.2 No.108 - 14, UL Standard No. 778.

Operating range
from 4.4 to 105.7 gpm (1 to 24 m³/h) with head up to 39 ft (12 m)

Liquid temperature range
from 32°F to +95°F (0°C to +35°C)

Pumped liquid
Sewage water with maximum solid particle size 1.5" (38mm)

Max. immersion depth 23 ft (7 m)

TECHNICAL DATA

MODEL	CODE	ELECTRICAL DATA						
		VOLTAGE 60 Hz	P1 MAX kW	P2 NOMINAL		In A	CAPACITOR	
				kW	HP		μF	Vc
FEKA BVP 700 M-A	60152204	1x115 V~	1.10	0.71	0.95	10.4	30	250
FEKA BVP 750 M-A	60146279	1x115 V~	1.10	0.71	0.95	10.5	30	250

RANGE PERFORMANCE

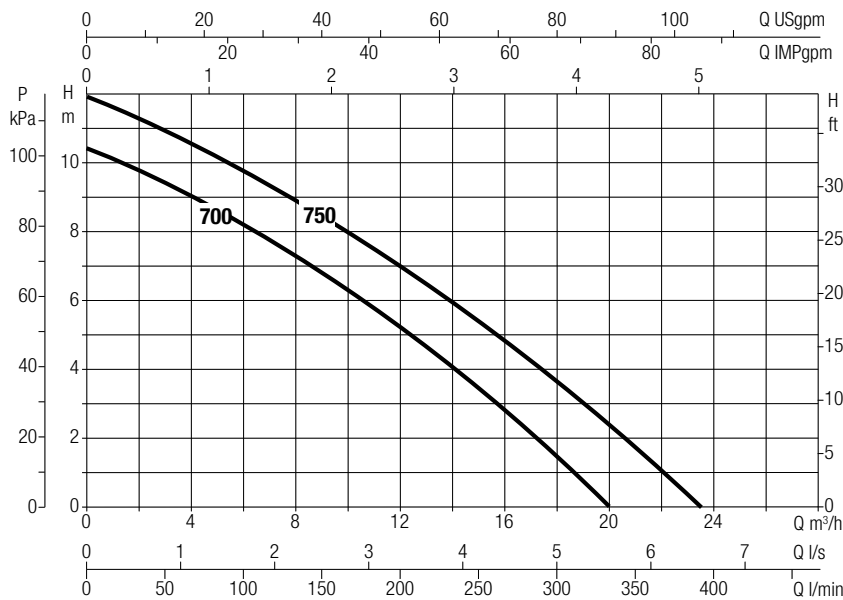

DIMENSIONS

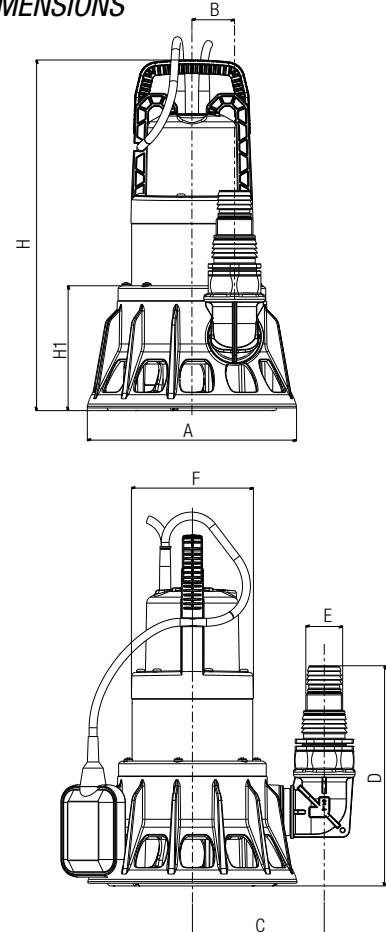

DIMENSIONS AND WEIGHT

MODEL	units	A	B	C	D	E (NPT)	F	H	H1	DNM (NPT)	CABLE ft	WEIGHT lbs	Q.TY x PALLET
FEKA BVP 700 M-A	inch	9.4	1.9	5.9	9.8	1" 1/4	5.5	15.7	5.6	1" 1/2	16 ft	17.6 lbs	27
	mm	240	49	150	250	140	140	400	142	1" 1/2	5 m	8 Kg	
FEKA BVP 750 M-A	inch	9.4	1.9	5.9	9.8	1" 1/4	5.5	15.7	5.6	1" 1/2	16 ft	17.6 lbs	27
	mm	240	49	150	250	140	140	400	142	1" 1/2	5 m	8 Kg	

