

FEKA VS

SEWAGE PUMPS



Submersible centrifugal pump with liquid vortex cast stainless steel impeller, suitable for pumping sewage water and waste water in general containing solids up to a maximum size of 2" (50 mm).

Handle with insulating rubber cover. AISI 316 stainless steel drive shaft. Double mechanical seal with intermediate oil chamber (atoxic oil), in carbon/alumina on the motor side and silicon carbide/silicon carbide on the pump side.

Dry, asynchronous, sealed and cooled by the pumped liquid. Rotor mounted on greased for-life ball bearings, oversized and selected to guarantee greater noise reduction and duration. Thermal protection as standard for single-phase version, and the user's responsibility for the three-phase version. Constantly active capacitor on the single-phase version. In compliance with CSA Standards C22.2 No.108 - 14, UL Standard No. 778.

Motor protection class IP 68

Insulation class F

Power supply cable

33 ft (10 m) of cable with plug for the single-phase version and 33 ft (10 m) of cable for the three-phase version

Operating range

from 0 to 140.9 GPM with head up to 46 ft

Pumped liquid

sewer water and waste water in general and non aggressive

Liquid temperature range

from 32°F to 95°F (0°C to +35°C) for household use from 32°F to 122°F (0°C to +50°C) for other uses

Maximum ambient temperature for pump

running with submerged motor +104 F (+40°C)

Maximum immersion depth 33 ft (10 m)

Installation fixed or portable, vertical

Free Passage 2 in (50 mm)



ACCESSORIES
PAG. 149

TECHNICAL DATA

MODEL	CODE	ELECTRICAL DATA						
		VOLTAGE 60 Hz	P1 MAX kW	P2 NOMINAL		In A	CAPACITOR	
				kW	HP		µF	VC
FEKA VS 550 M-A	60193434	1 ~ 115V 60Hz	0.84	0.55	0.75	8.7	50	200
FEKA VS 550 M-A	60193436	1 ~ 220-230V 60Hz	0.91	0.55	0.75	3.9 - 4	20	450
FEKA VS 550 M-NA	60193440	1 ~ 115V 60Hz	0.84	0.55	0.75	8.7	50	200
FEKA VS 550 M-NA	60193442	1 ~ 220-230V 60Hz	0.91	0.55	0.75	3.9 - 4	20	450
FEKA VS 550 T-NA*	60193446	3 ~ 220-277V 60Hz	0.80	0.55	0.75	2.72 - 2.42	-	-
FEKA VS 1000 M-A	60193438	1 ~ 220-230V 60Hz	1.28	1.00	1.36	6.63	25	450
FEKA VS 1000 M-NA	60193444	1 ~ 220-230V 60Hz	1.28	1.00	1.36	6.63	25	450
FEKA VS 1000 T-NA*	60193448	3 ~ 220-277V 60Hz	1.19	1.00	1.36	2.51	-	-
FEKA VS 1200 M-A	60193439	1 ~ 220-230V 60Hz	1.76	1.20	1.60	8.63	30	450
FEKA VS 1200 M-NA	60193445	1 ~ 220-230V 60Hz	1.76	1.20	1.60	8.63	30	450
FEKA VS 1200 T-NA*	60193449	3 ~ 220-277V 60Hz	1.74	1.20	1.60	3.44	-	-

* 3x220/277 V ~ available on request

FEKA VS

SEWAGE PUMPS

RANGE PERFORMANCE

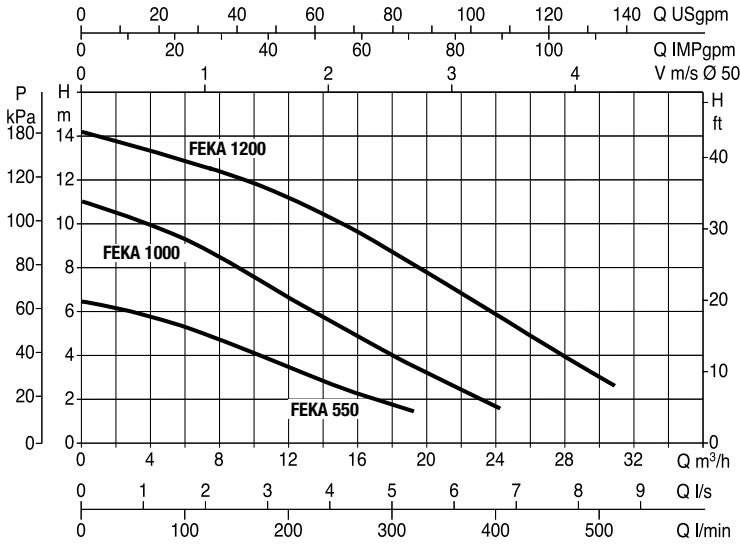

DIMENSIONS AND WEIGHT

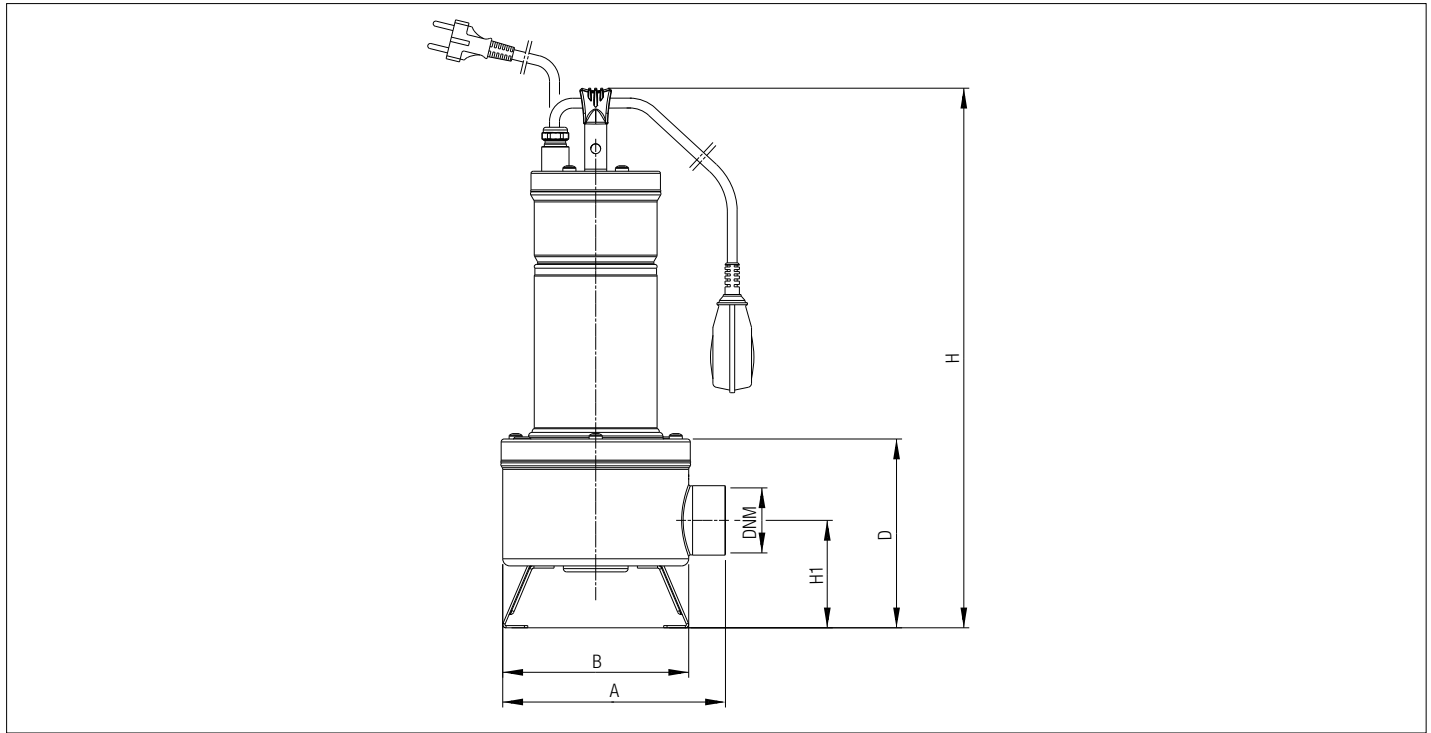

MODEL	unit	A	B	D	H	H1	Ø DNM (NPT)	PACKING DIMENSIONS			CABLE LENGHT	FREE PAS- SAGE	WEIGHT	Q.TY x PALLET
								L/A	L/B	H				
FEKA VS 550	inch	8	6.7	6.8	19.4	3.9	2"	9.4	23.6	9.4	33 ft	2	35.9 lbs	24
	mm	203	170	172	492	98		240	600	240	10 m	50	16.3 Kg	
FEKA VS 1000	inch	8	6.7	6.8	21.1	3.9	2"	9.4	23.6	9.4	33 ft	2	38.6 lbs	24
	mm	203	170	172	537	98		240	600	240	10 m	50	17.5 Kg	
FEKA VS 1200	inch	8	6.7	6.8	21.1	3.9	2"	9.4	23.6	9.4	33 ft	2	45.9 lbs	24
	mm	203	170	172	537	98		240	600	240	10 m	50	17.5 Kg	