

6GF HEAVY DUTY

6" SUBMERSIBLE MOTORS - 60 Hz



6GF HEAVY DUTY

6" SUBMERSIBLE MOTORS



TECHNICAL DATA

Maximum operating depth: 984 ft (300 m)

Standard flanges: NEMA 6"

Maximum number of starts per hour: 25/h

Motor protection class: IP 68

Motor insulation class: F

Cooling flow speed: min. 0.1 ft/s (0.3 m/s) at 95°F (35°C)

Max Thrust load: 11,240 lbf (50 kN)

Three phase power input: 3x400V 50 Hz / 3x460V 60 Hz

Power input tolerance: +6% / -10%

Power cable: 30 & 40Hp 13.1 ft (4 m)

50 & 60Hp 19.7 ft (6m)

Possible type of installation: vertical

Special versions on request: it is available with additional PT100 or PTC temperature sensor. Voltage and power cables of different length.

Cable certifications: ACS, WRAS and KTW certified cable

6" canned submersible motor made in AISI 304 and cathaphoresis treated cast iron. Resin filled stator. Cooling and lubrication are guaranteed by a mixture of water and glycol. 6GF heavy duty motors are design for very deep borehole installation.

CONSTRUCTION FEATURES OF THE MOTOR

Two pole asynchronous motor in AISI 304 stainless steel and cathaphoresis treated cast iron for parts in contact with water. Cooling and lubrication of the thrust unit and bushings guaranteed by a mixture of water and glycol. Mitchell type self-centering thrust unit with 11,240 lbf (50kN) axial load. The stator is filled with resin with high heat dissipation capacity. Removable cable connector. ACS, WRAS and KTW certified cable. Motor suitable for use with variable frequency drive (30 Hz - 60 Hz). The protection must be guaranteed by the user. Available with direct or star-delta start. It is available with additional PT100 or PTC temperature sensor.

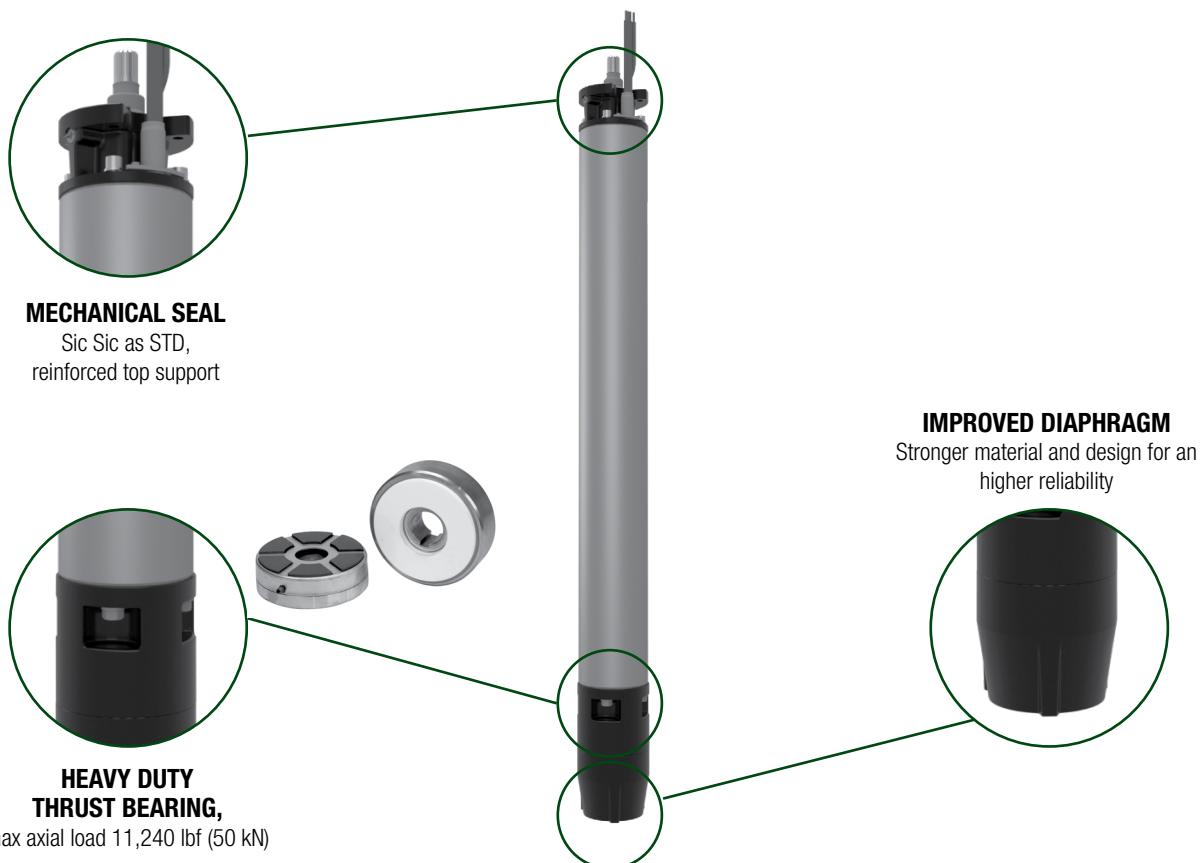

6GF HEAVY DUTY

6" SUBMERSIBLE MOTORS

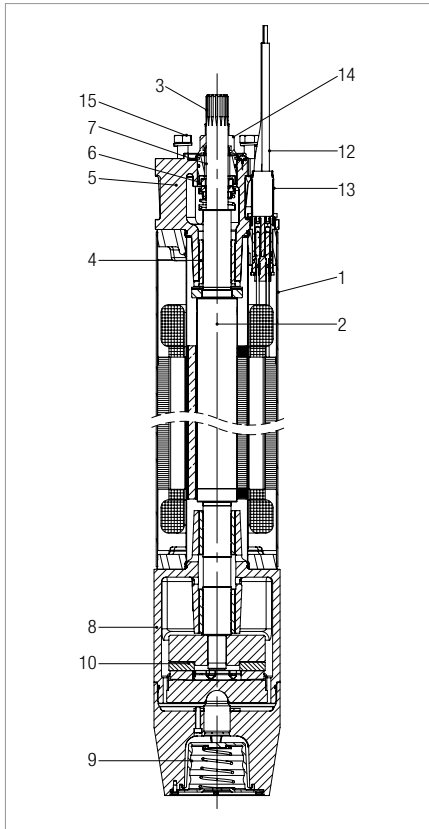

MATERIALS

N°	PARTS	MATERIALS
1	EXTERNAL SLEEVE	STAINLESS STEEL EN 1.4307 - AISI 304L
2	SHAFT	STEEL ASTM A 105
3	SHAFT END	STAINLESS STEEL EN 1.4404 - AISI 316L
4	BUSHINGS	GRAPHITE
5	UPPER BRACKET	CAST IRON EN 0.6020 + CATAPHORESIS COATING
6	MECHANICAL SEAL	SIC - SIC
7	GASKET	NBR
8	LOWER BRACKETS	CAST IRON EN 0.6025 + CATAPHORESIS COATING
9	DIAPHRAGM	FKM
10	THRUST BEARING	CERAMIC - GRAPHITE
11	VALVE	BRASS CW614N
12	CABLE EU	FLAT - 07XBH2-F
	CABLE US	RHW-2 OR RHW OR RHH 600V
13	CONNECTING PLUG	STAINLESS STEEL EN 1.4301 - AISI 304
14	SAND GUARD	NBR 70
15	BOLTS & SCREWS	STEEL A2-70 - AISI 304
16	COOLING LIQUID	WATER + GLYCOL

DIMENSIONS

MODEL	LENGTH inch (mm)	MOTOR DIAMETER Inch (mm)	AXIAL THRUST lbf (Nm)	WEIGHT Lbs	PACKING DIMENSIONS Inch (mm)		
					L	B	H
6GF - 22 KW - HD	40" (1,016)	5.67 (144)	11,240 (50000)	240 (109)	63 (1600)	11 (280)	16 (406)
6GF - 30 KW - HD	45" (1,143)	5.67 (144)	11,240 (50000)	262 (119)	63 (1600)	11 (280)	16 (406)
6GF - 37 KW - HD	50" (1,270)	5.67 (144)	11,240 (50000)	291 (132)	63 (1600)	11 (280)	16 (406)
6GF - 45 KW - HD	57" (1,447)	5.67 (144)	11,240 (50000)	331 (150)	68 (1727)	11 (280)	16 (406)

ELECTRICAL DATA

MODEL	P2		VOLTAGE 60 Hz	P1 (W)	SF	IN (A)	I SF	Is/In	rpm	MOTOR EFFICIENCY η (Eff.) [%] at % load			POWER FACTOR $\cos \phi$ (Pf.) at % load			CABLE	
	(HP)	KW								50	75	100	50	75	100	Ø AWG	LC ft (m)
6GF - 22 KW - HD	30	22	3x460V~	26500	1.15	44.7	49.8	5.8	3480	79	82	83	0.61	0.70	0.75	AWG10	13.1 (4)
6GF - 30 KW - HD	40	30	3x460V~	35500	1.15	54	62	6.3	3480	80	83	84	0.69	0.79	0.83	AWG8	13.1 (4)
6GF - 37 KW - HD	50	37	3x460V~	45000	1.15	69	77	6.1	3480	80	82	83	0.66	0.76	0.82	AWG8	19.7 (6)
6GF - 45 KW - HD	60	45	3x460V~	55000	1.15	82	92	6.5	3450	79	83	84	0.67	0.77	0.83	AWG8	19.7 (6)

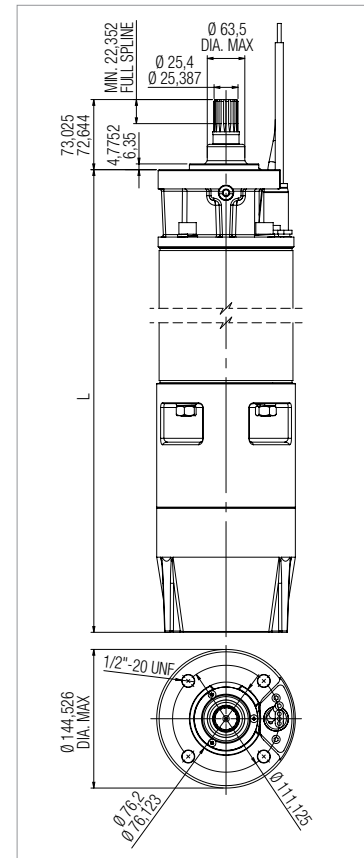

DNA[®]

PUMPS SELECTOR

On-line product selection



DAB PUMPS LTD.
6 Gilbert Court
Newcomen Way
Severalls Business Park
Colchester
Essex
CO4 9WN - UK
salesuk@dwtgroup.com
Tel. +44 0333 777 5010



DAB PUMPS BV
'tHofveld 6 C1
1702 Groot Bijgaarden - Belgium
info.belgium@dwtgroup.com
Tel. +32 2 4668353



DAB PUMPS B.V.
Albert Einsteinweg, 4
5151 DL Drunen - Nederland
info.netherlands@dwtgroup.com
Tel. +31 416 387280
Fax +31 416 387299



DAB PUMPS GMBH
Am Nordpark 3
D - 41069 Mönchengladbach - Germany
info.germany@dwtgroup.com
Tel. +49 2161 47388-0
Fax +49 2161 47388-36



DAB PUMPS IBERICA S.L.
Calle Verano 18-20-22
28850 - Torrejón de Ardoz - Madrid
Spain
Info.spain@dwtgroup.com
Tel. +34 91 6569545
Fax: + 34 91 6569676



DAB PUMPS HUNGARY KFT.
H-8800
Nagykanizsa, Buda Ernő u.5
Hungary
Tel. +36 93501700



DAB PUMPS POLAND Sp. z o.o.
Ul. Janka Muzykanta 60
02-188 Warszawa - Poland
polska@dabpumps.com.pl



OOO DAB PUMPS
Novgorodskaya str. 1, block G
office 308, 127247, Moscow - Russia
info.russia@dwtgroup.com
Tel. +7 495 122 0035
Fax +7 495 122 0036



DAB PUMPS INC.
3226 Benchmark Drive
Ladson, SC 29456 - USA
info.usa@dwtgroup.com
Tel. 1- 843-797-5002
Fax 1-843-797-3366



DAB PUMPS SOUTH AFRICA (PTY) LTD
Twenty One industrial Estate,
16 Purlin Street, Unit B, Warehouse 4
Olifantsfontein -1666 - South Africa
info.sa@dwtgroup.com
Tel. +27 12 361 3997



DAB PUMPS (QINGDAO) CO. LTD.
No.40 Kaituo Road, Qingdao Economic & Technological
Development Zone
Qingdao City, Shandong Province - China
PC: 266500
sales.cn@dwtgroup.com
Tel. +86 400 186 8280
Fax +86 53286812210



DAB PUMPS DE MÉXICO, S.A. DE C.V.
Av Amsterdam 101 Local 4
Col. Hipódromo Condesa,
Del. Cuauhtémoc CP 06170
Ciudad de México
Tel. +52 55 6719 0493



DAB PUMPS OCEANIA PTY LTD
426 South Gippsland Hwy,
Dandenong South VIC 3175 - Australia
info.oceania@dwtgroup.com
Tel. +61 1300 378 677



PT DAB PUMPS INDONESIA
Satrio Tower lantai 26
unit C-D, Jl. Prof. Dr. Satrio Kav. C4,
Kel. Kuningan Timur, Kec. Setiabudi, Kota Adm.
Jakarta Selatan, Prov. DKI Jakarta. - Indonesia
Tel. +62 2129222850