

Technical Data

TECHNICAL DATA

Flow rate maximum: from 3 GPM to 18 GPM

Head up to: 538ft

Maximum immersion depth: 490 ft

Type of pumped liquid: clean, free from solid or abrasive substances, non-viscous, non-aggressive, non-crystallized and chemically neutral.

Liquid temperature range: min 0°C/32°F - max 40°C/104°F

Delivery: 1" 1/4 NPT

Impeller/s material: technopolymer

Maximum number of starts: 20/h

Protection class: IP 68

Motor insulation class: F

Power cable (m) and plug: 5ft/1.5m

Single phase power input: 230V(±6%) 60 Hz

Three phase power input: not available

Possible type of installation: in vertical position.

If it is installed in horizontal position it is necessary to ensure a minimum load on the thrust unit and the cooling sleeve.

Certification: CSA, NSF

APPLICATIONS

3" submersible multi-impeller pump for 3" or larger wells for pressurization, lifting water from underground, gardening and irrigation activities in residential building service.

Ready-to-use pump.

CONSTRUCTION FEATURES OF THE PUMP

Technopolymer impellers housed with stainless steel adjustment rings. Pump liner, shaft, coupling with motor, integrated suction filter and cable guard are in stainless steel. Suction and delivery supports in micro-cast AISI 304 stainless steel. Removable built-in non-return valve in technopolymer. Technopolymer impellers. NSF61 certificate is pending approval.

CONSTRUCTION FEATURES OF THE MOTOR

Two-pole asynchronous motor completely made of AISI 304 stainless steel. Two wire version. The thrust block and bushes are cooled and lubricated with a mixture of water and glycol. Rotor mounted on a Kingsbury type self-centering thrust block capable of withstanding high axial loads.

The stator is immersed in thermosetting insulating resin with high heat dissipation capacity and encapsulated in an airtight AISI 304 stainless steel casing.

Removable cable connector CSA approved.



WATER • TECHNOLOGY

<http://www.dabpumps.us>



WATER • TECHNOLOGY

TYPICAL INSTALLATION

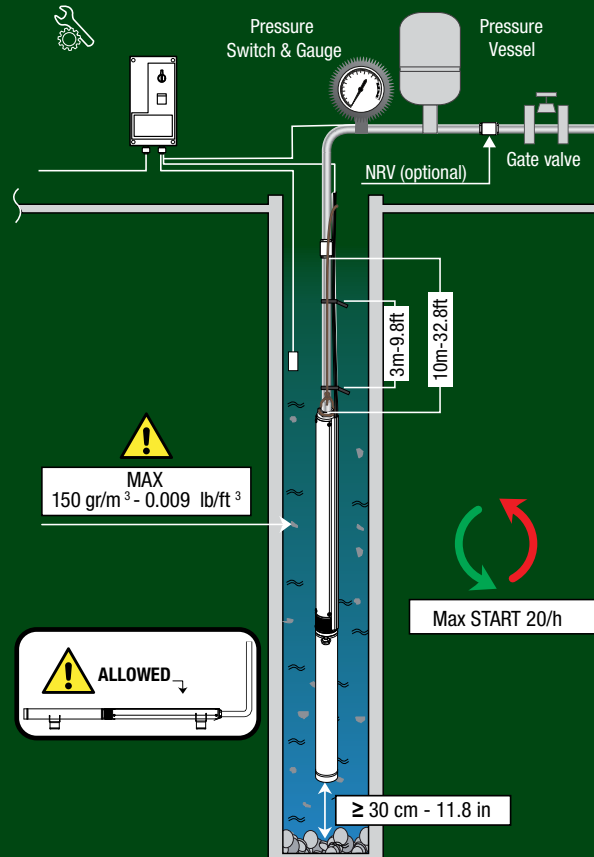

S3 60Hz

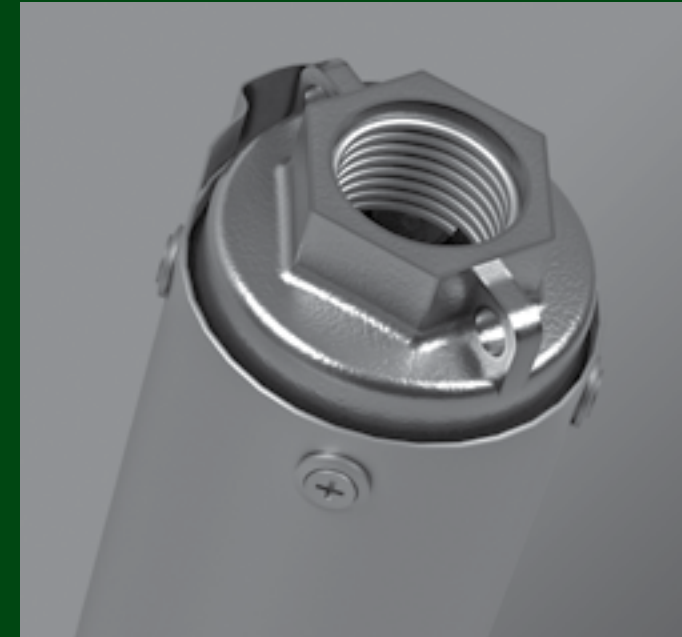

SUBMERSIBLE PUMPS AND MOTORS



DAB PUMPS INC.

3226 Benchmark Drive

Ladson, SC 29456 - USA

service.us@dabpumps.com

Tel. 1-843-797-5002

Fax 1-843-797-3366



Drinking Water
NSF / ANSI 61



Low Lead Content
NSF / ANSI 372

S3 05 GPM

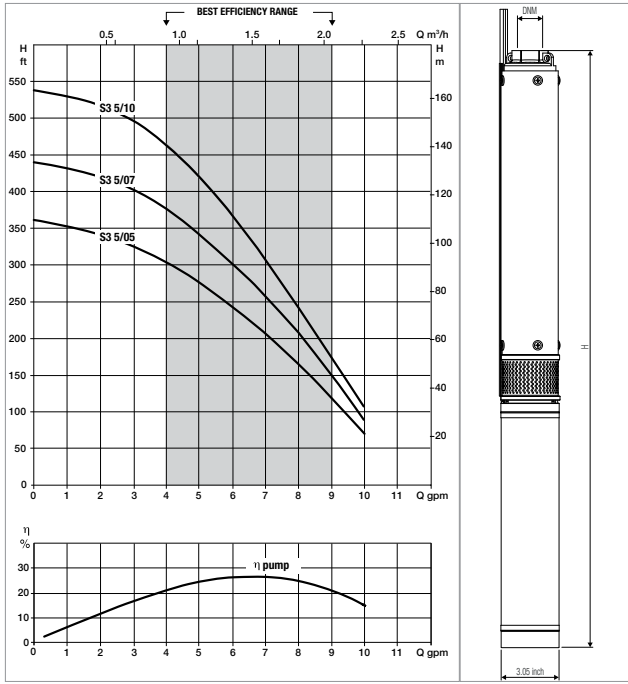

MODEL	HYDRAULIC DATA						
	Q=gpm	0	2	4	6	8	10
S3 5/05	H (ft)	362	342	304	244	165	70
S3 5/07		440	422	375	302	208	90
S3 5/10		538	524	464	368	242	106

MODEL	ELECTRICAL DATA						
	Stages	Voltage	P2 Nominal		In Amps	SF Amps	Capacitor
			P2 kW	P2 Hp			
S3 5/05	24	230v	0.37	0.5	4.7	6.0	16 uF
S3 5/07	29	230v	0.55	0.75	6.1	7.0	20 uF
S3 5/10	35	230v	0.75	1.0	8.3	9.8	20 uF

MODEL	WEIGHTS AND DIMENSIONS						
	Ø	H	DNM NPT	PACKING DIMENSIONS			Gross weight
				Length	Width	Height	
S3 5/05	2.91"	52.0"	1" 1/4	68.9"	6.7"	5.9"	38 lbs
S3 5/07	2.91"	60.3"	1" 1/4	68.9"	6.7"	5.9"	42 lbs
S3 5/10	2.91"	68.8"	1" 1/4	68.9"	6.7"	5.9"	47 lbs

S3 10 GPM

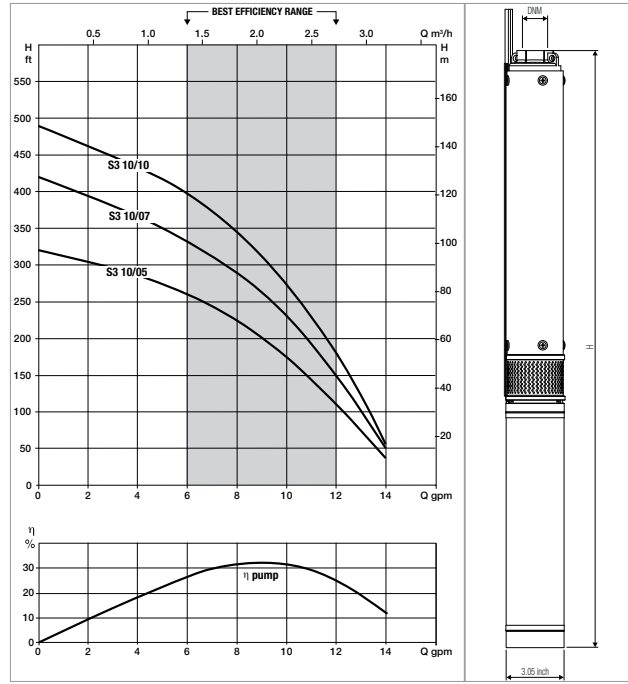

MODEL	HYDRAULIC DATA									
	Q=gpm	0	2	4	6	8	10	12	14	
S3 10/05	H (ft)	320	304	286	260	224	174	110	36	
S3 10/07		420	394	366	334	290	230	150	50	
S3 10/10		490	462	436	400	348	270	180	60	

MODEL	ELECTRICAL DATA						
	Stages	Voltage	P2 Nominal		In Amps	SF Amps	Capacitor
			P2 kW	P2 Hp			
S3 10/05	21	230v	0.37	0.5	4.7	6.0	16 uF
S3 10/07	27	230v	0.55	0.75	6.1	7.0	20 uF
S3 10/10	31	230v	0.75	1.0	8.3	9.8	20 uF

MODEL	WEIGHTS AND DIMENSIONS						
	Ø	H	DNM NPT	PACKING DIMENSIONS			Gross weight
				Length	Width	Height	
S3 10/05	2.91"	48.9"	1" 1/4	68.9"	6.7"	5.9"	37 lbs
S3 10/07	2.91"	58.2"	1" 1/4	68.9"	6.7"	5.9"	42 lbs
S3 10/10	2.91"	64.7"	1" 1/4	68.9"	6.7"	5.9"	46 lbs

S3 15 GPM

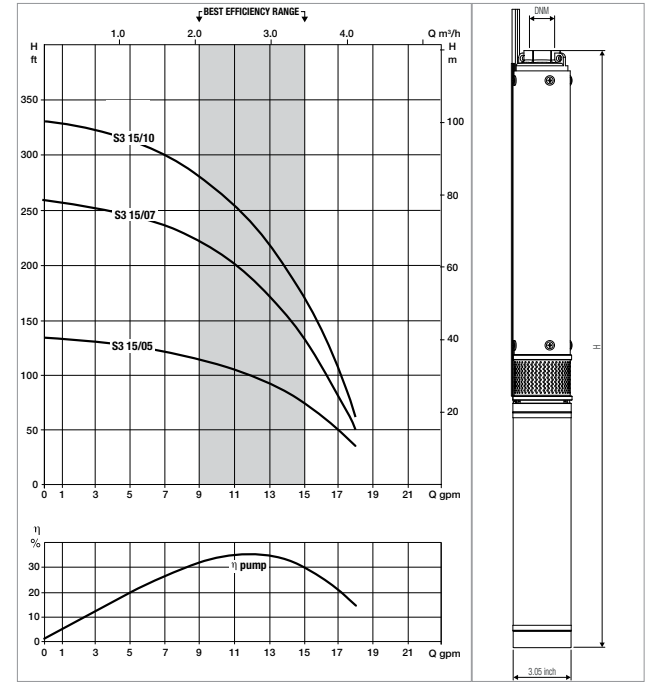

MODEL	HYDRAULIC DATA													
	Q=gpm	0	2	4	6	8	10	12	14	16	18			
S3 15/05	H (ft)	134	132	130	125	118	110	98	84	64	35			
S3 15/07		260	258	250	242	230	212	188	154	110	52			
S3 15/10		332	330	320	310	292	268	236	194	138	60			

MODEL	ELECTRICAL DATA						
	Stages	Voltage	P2 Nominal		In Amps	SF Amps	Capacitor
			P2 kW	P2 Hp			
S3 15/05	8	230v	0.37	0.5	4.7	6.0	16 uF
S3 15/07	16	230v	0.55	0.75	6.1	7.0	20 uF
S3 15/10	21	230v	0.75	1.0	8.3	9.8	20 uF

MODEL	WEIGHTS AND DIMENSIONS						
	Ø	H	DNM NPT	PACKING DIMENSIONS			Gross weight
				Length	Width	Height	
S3 15/05	2.91"	34.1"	1" 1/4	68.9"	6.7"	5.9"	33 lbs
S3 15/07	2.91"	43.8"	1" 1/4	68.9"	6.7"	5.9"	38 lbs
S3 15/10	2.91"	52.9"	1" 1/4	68.9"	6.7"	5.9"	43 lbs