



esybox MAX

ELECTRONIC BOOSTER SET



ESYBOX MAX

ELECTRONIC BOOSTER SET



TECHNICAL DATA

Flow rate: Up to 76 gpm (17,4 m³/h) For single unit

Head: 370 ft (113 m)

Type of pumped liquid: Clean, free from solid or abrasive substances, non-viscous, non-aggressive, non-crystallized and chemically neutral

Liquid temperature: +104°F (45°C)

Maximum ambient temperature: +113°F (45°C)

Maximum inlet pressure: 72psi (5 bar)

Operation pressure: 174psi (12 bar / 1200 kPa)

Constant pressure range: 15-174 (1-12 bar)

Pre-set Pressure: 45psi (3 bar)

Motor protection class: IP X5

Motor insulation class: F

Impeller material: Technopolymer

Single phase power input: 208-240V 50/60Hz

Three phase power input: 380-480V 50/60Hz

Type of installation: Fixed in vertical position

Certification:

CSA C22.2 No. 108-14- 5th Ed. – Liquid Pumps.

UL 778 6th Ed. – Motor Operated Water Pumps

NSF 61 Drinking Water

NSF 372 Drinking Water - Low Lead Content

Integrated pumping system for pressurization in commercial building service. Available in two power sizes, it consists of modular elements that allow different configurations to cover the needs of medium/large condominiums and high buildings (even over 14 floors).

Each unit consists of the single, double or triple connection base and the pumping units; a four-pumps system is available with the additional kit to connect two double bases.

The modular construction allows to assemble the pumping groups directly at the installation site (O.S.A. concept).

The silence and compactness of dimensions allow installation in all rooms, even inhabited.

CONSTRUCTION FEATURES OF THE PUMP

Electronic vertical multi-impeller pump, with display, pressure sensors on intake and delivery, non-return valve on delivery and an integrated expansion tank. Pump body and impellers in technopolymer with steel jacket.

CONSTRUCTION FEATURES OF THE MOTOR

Water-cooled permanent magnet motor, stainless steel motor jacket. Motor shaft in AISI 303 stainless steel.

CONSTRUCTION FEATURES OF THE ELECTRONIC

The variable frequency drive keeps the pressure constant by varying the number of motor revolutions according to the request.

The expansion module (esy I/O, available as an accessory) makes it possible to interface Esybox Max with the other elements of the system (BMS).

Integrated protections: protection from dry running, amperometric and abnormal voltages, overheating, freezing, anti-blocking and anti-cycling.

DCONNECT

It is possible to configure and view the operating parameters on the large Esybox Max display or thanks to the DConnect app and the integrated Wi-Fi module, it is possible to do it remotely with an active DConnect service (an Internet connection is required).

From a smartphone or a tablet it is possible to control and manage system pressure, alarms and check the instantaneous and historical consumption.

With DSync technology, the user experience of Esybox Max is simplified. Using their smartphone or tablet, the installer interfaces with the pump that automatically detects the language, the time and the unit of measurement used in the Country of installation. In the case of a booster set, once the installation of the first pump is completed, the Esybox Max automatically synchronize the other pumps. The DSync also allows you to connect the pump to the outside world, through the Modbus protocol.

MATERIAL

N°	PARTS	MATERIALS
1	FITTING	TECHNOPOLYMER PA66 30%GF
2	MANIFOLD	AISI 304 STEEL
3	FLANGE	TECHNOPOLYMER PA66 30%GF
4	PUMP BODY	TECHNOPOLYMER PA66 30%GF
5	PUMP BODY RING	TECHNOPOLYMER PP 30%GF
6	IMPELLER	TECHNOPOLYMER PPO 30%GF / AISI 304 STEEL
7	DIFFUSER	TECHNOPOLYMER PPO 30%GF / AISI 304 STEEL
8	MOTOR AXIS	AISI 303 STEEL
9	O-RING	EPDM
10	O-RING	EPDM
11	MOTOR FLANGE	TECHNOPOLYMER PA66 30%GF
12	MECHANICAL SEAL	GRAPHITE / STAINLESS STEEL / EPDM
13	O-RING	EPDM
14	MOTOR LINER	AISI 304 STEEL
15	MOTOR BODY	TECHOPOLYMER PA66 30%GF
16	O-RING	EPDM
17	CONVEYOR TUBE	TECHNOPOLYMER PP 30%GF
18	PRESSURE SENSOR	NYLON / EPDM
19	NON RETURN VALVE	POM / EPDM / AISI 302 STEEL
20	NON RETURN VALVE BODY	TECHNOPOLYMER PA66 30%GF
21	TANK	NORYL / GOMMA
22	DELIVERY BODY	TECHNOPOLYMER PA66 30%GF
23	OUTER LINER	AISI 304 STEEL

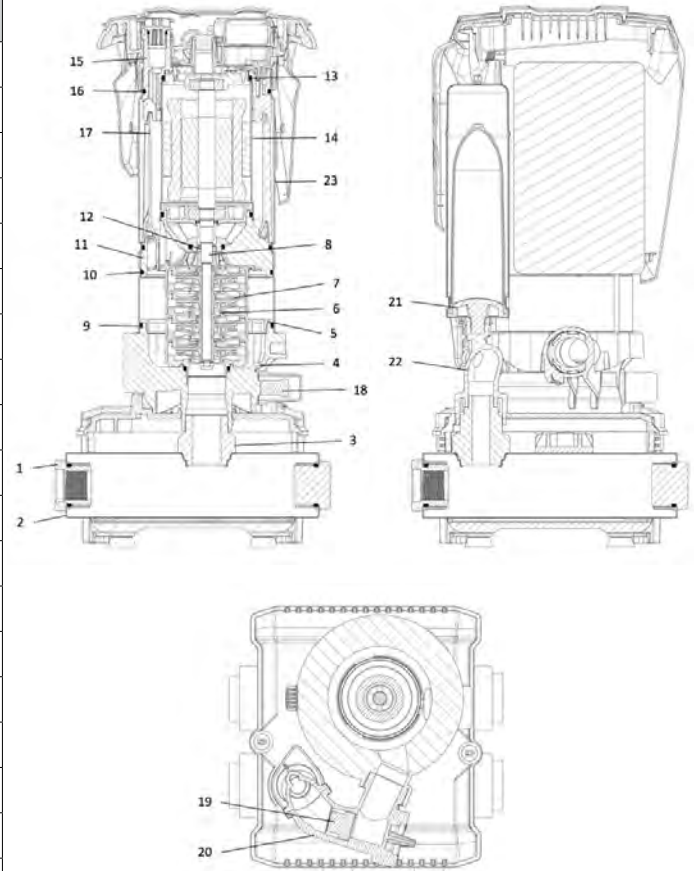

ESYBOX LINE

ELECTRONIC BOOSTER SET

PERFORMANCE RANGE

The performance curves are based on kinematic viscosity values = 1 mm²/s and density equivalent to 1000 kg/m³. Curve tolerance according to ISO 9906.

GRAPHIC SELECTION TABLE

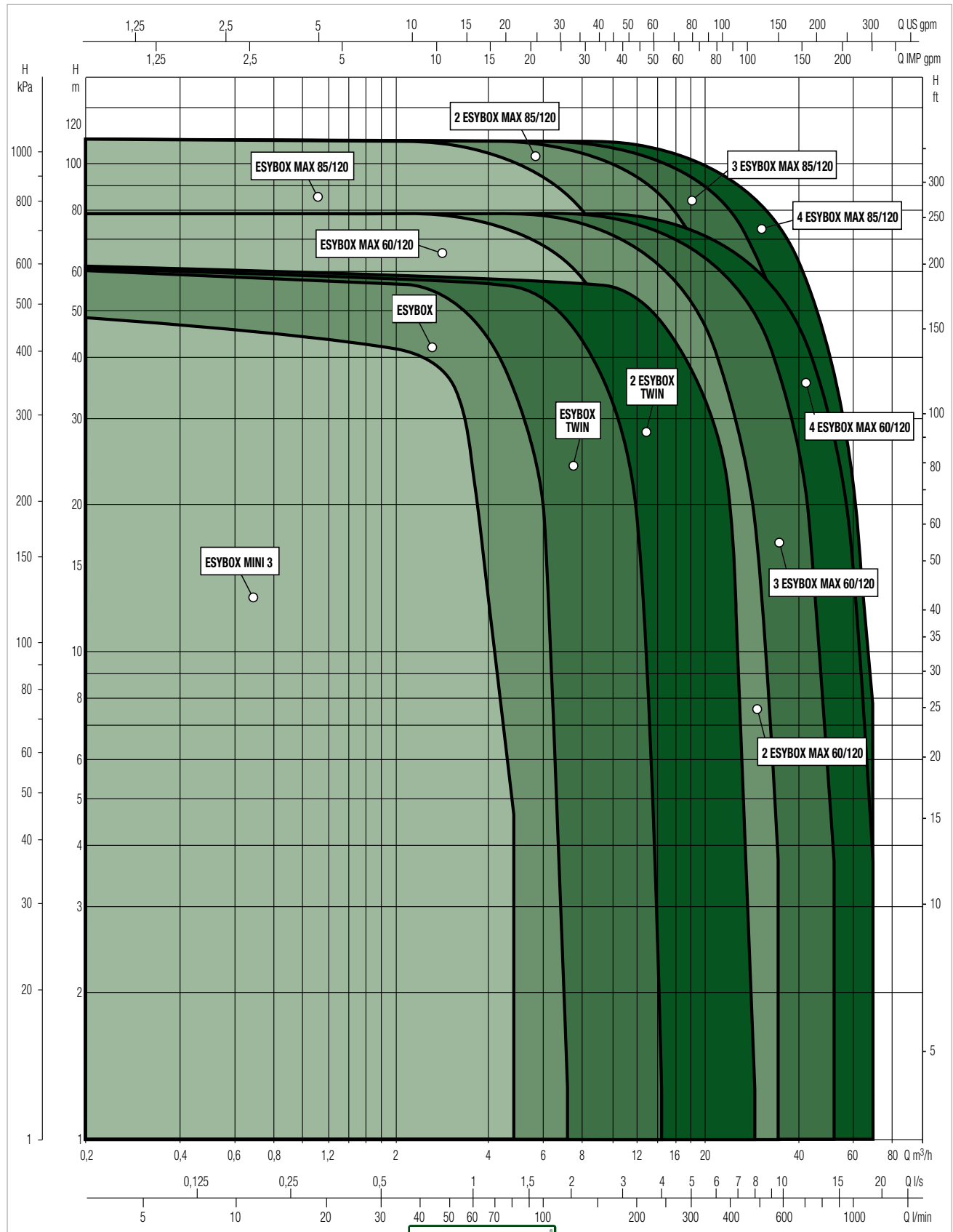

SELECTION TABLE

MODEL	Q=gpm	0	10.6	15.9	21.1	26.4	31.7	37.0	42.3	47.6	55.5	63.4	76.6
	Q=l/min	0	40	60	80	100	120	140	160	180	210	240	290
ESYBOX MAX 45/120 M	H=ft	190.3	190.3	190.3	190.3	170.6	147.6	126.3	116.5	85.3	53.5	23	
	H=m	58	58	58	58	52	45	38.5	35.5	26	16.3	7	
ESYBOX MAX 60/120 M	H=ft	262.5	260.8	253.0	240.8	224.7	203.4	182.1	158.1	134.5	100.1	68.9	13.1
	H=m	80	79.5	77.1	73.4	68.5	62	55.5	48.2	41	30.5	21	4
ESYBOX MAX 60/120 T	H=ft	262.5	260.8	253.0	240.8	224.7	203.4	182.1	158.1	134.5	100.1	68.9	13.1
	H=m	80	79.5	77.1	73.4	68.5	62	55.5	48.2	41	30.5	21	4
ESYBOX MAX 85/120 T	H=ft	370.7	360.9	349.4	331.4	305.1	275.6	246.1	214.9	186.0	142.7	101.7	27.9
	H=m	113	110	106.5	101	93	84	75	65.5	56.7	43.5	31	8.5

MODEL	Q=gpm	0	21.1	31.7	42.3	52.8	63.4	74.0	84.5	95.1	111.0	126.8	153.2
	Q=l/min	0	80	120	160	200	240	280	320	360	420	480	580
2 ESYBOX MAX 45/120 M	H=ft	190.3	190.3	190.3	190.3	170.6	147.6	126.3	116.5	85.3	53.5	23	
	H=m	58	58	58	58	52	45	38.5	35.5	26	16.3	7	
2 ESYBOX MAX 60/120 M	H=ft	262.5	260.8	253.0	240.8	224.7	203.4	182.1	158.1	134.5	100.1	68.9	13.1
	H=m	80	79.5	77.1	73.4	68.5	62	55.5	48.2	41	30.5	21	4
2 ESYBOX MAX 60/120 T	H=ft	262.5	260.8	253.0	240.8	224.7	203.4	182.1	158.1	134.5	100.1	68.9	13.1
	H=m	80	79.5	77.1	73.4	68.5	62	55.5	48.2	41	30.5	21	4
2 ESYBOX MAX 85/120 T	H=ft	370.7	360.9	349.4	331.4	305.1	275.6	246.1	214.9	186.0	142.7	101.7	27.9
	H=m	113	110	106.5	101	93	84	75	65.5	56.7	43.5	31	8.5

MODEL	Q=gpm	0	31.7	47.6	63.4	79.3	95.1	111.0	126.8	142.7	166.4	190.2	229.8
	Q=l/min	0	120	180	240	300	360	420	480	540	630	720	870
3 ESYBOX MAX 45/120 M	H=ft	190.3	190.3	190.3	190.3	170.6	147.6	126.3	116.5	85.3	53.5	23	
	H=m	58	58	58	58	52	45	38.5	35.5	26	16.3	7	
3 ESYBOX MAX 60/120 M	H=ft	262	261	253	241	225	203	182	158	135	100	69	13
	H=m	80	79.5	77.1	73.4	68.5	62	55.5	48.2	41	30.5	21	4
3 ESYBOX MAX 60/120 T	H=ft	262.5	260.8	253.0	240.8	224.7	203.4	182.1	158.1	134.5	100.1	68.9	13.1
	H=m	80	79.5	77.1	73.4	68.5	62	55.5	48.2	41	30.5	21	4
3 ESYBOX MAX 85/120 T	H=ft	370.7	360.9	349.4	331.4	305.1	275.6	246.1	214.9	186.0	142.7	101.7	27.9
	H=m	113	110	106.5	101	93	84	75	65.5	56.7	43.5	31	8.5

MODEL	Q=gpm	0	42.3	63.4	84.5	105.7	126.8	147.9	169.1	190.2	221.9	253.6	306.4
	Q=l/min	0	160	240	320	400	480	560	640	720	840	960	1160
4 ESYBOX MAX 45/120 M	H=ft	190.3	190.3	190.3	190.3	170.6	147.6	126.3	116.5	85.3	53.5	23	
	H=m	58	58	58	58	52	45	38.5	35.5	26	16.3	7	
4 ESYBOX MAX 60/120 M	H=ft	262.5	260.8	253.0	240.8	224.7	203.4	182.1	158.1	134.5	100.1	68.9	13.1
	H=m	80	79.5	77.1	73.4	68.5	62	55.5	48.2	41	30.5	21	4
4 ESYBOX MAX 60/120 T	H=ft	262.5	260.8	253.0	240.8	224.7	203.4	182.1	158.1	134.5	100.1	68.9	13.1
	H=m	80	79.5	77.1	73.4	68.5	62	55.5	48.2	41	30.5	21	4
4 ESYBOX MAX 85/120 T	H=ft	370.7	360.9	349.4	331.4	305.1	275.6	246.1	214.9	186.0	142.7	101.7	27.9
	H=m	113	110	106.5	101	93	84	75	65.5	56.7	43.5	31	8.5

ESYBOX MAX - ELECTRONIC BOOSTER SET

Liquid temperature: +104°F (40°C) - Maximum ambient temperature: + 113°F (45°C)

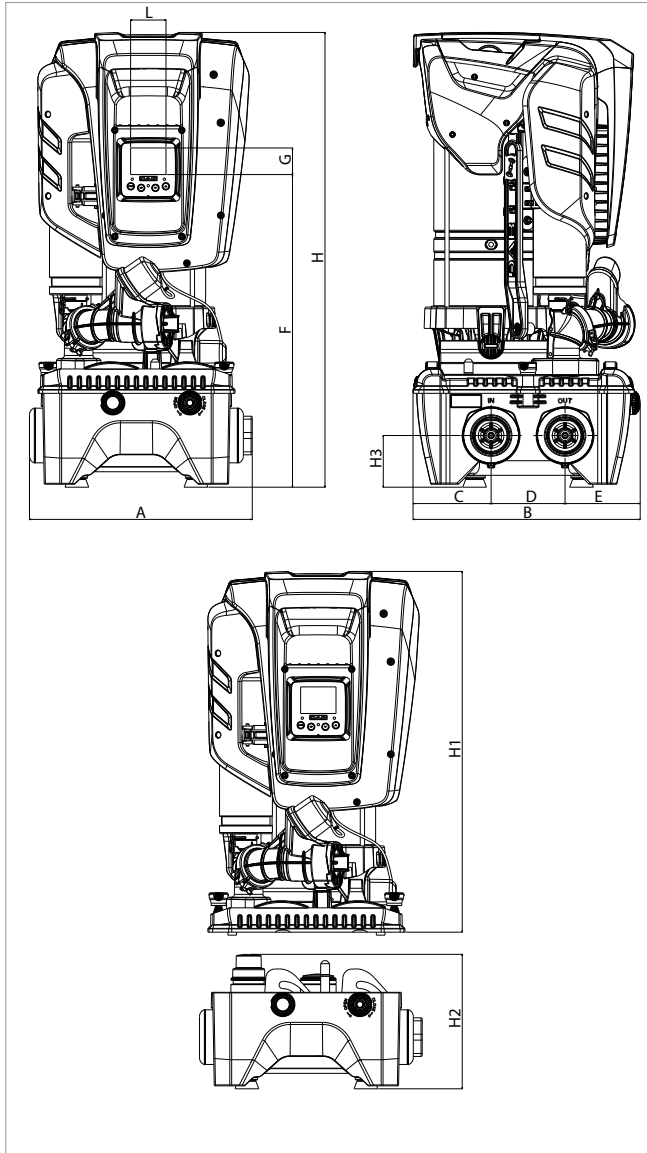

The performance curves are based on the kinematic viscosity values = 1 mm²/s and density equivalent to 1000 kg/m³. Curve tolerance according to ISO 9906.

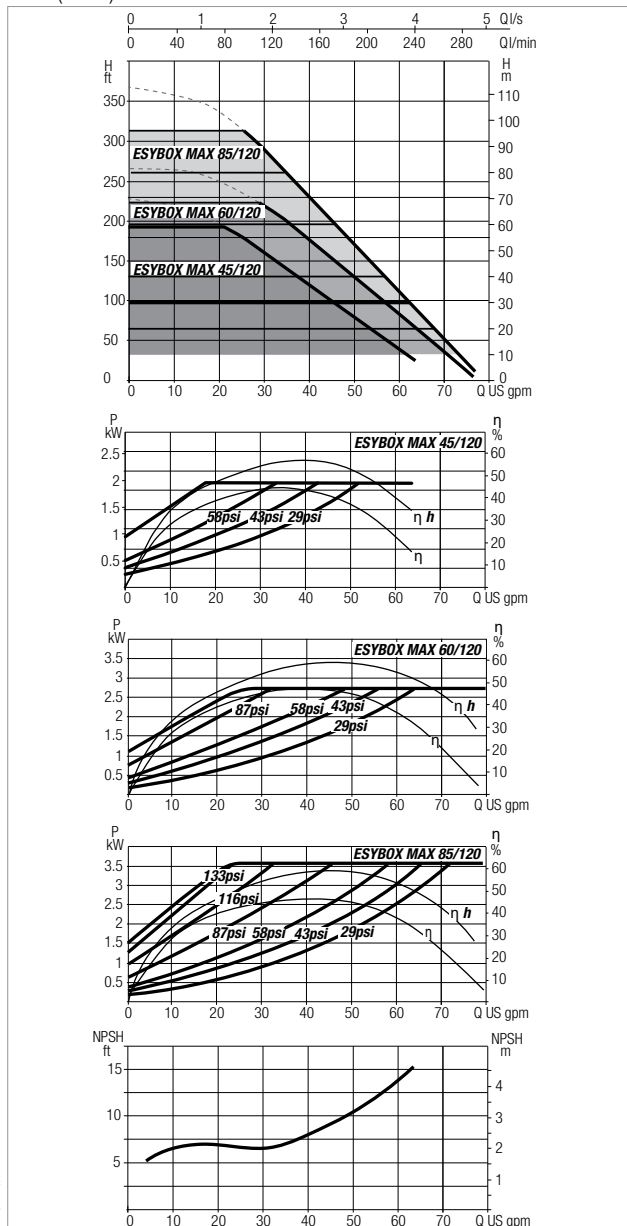

MODEL	N° IMPELLERS	POWER SUPPLY 50/60 Hz	ELECTRICAL DATA			
			P1 MAX		In A	SET POINT psi (bar)
			kW	HP		
ESYBOX MAX 45/120 M	3	1x208-240V ~	1.97	2.6	9.4	15 - 174 (1-12)
ESYBOX MAX 60/120 M	3	1x208-240V ~	2.68	3.6	12.5 - 11.5	15 - 174 (1-12)
ESYBOX MAX 60/120 T	3	3x380-480V ~	2.65	3.5	4.4	15 - 174 (1-12)
ESYBOX MAX 85/120 T	4	3x380-480 V ~	3.50	4.7	5.6	15 - 174 (1-12)

MODEL	A	B	C	D	E	F	G	H	H1	H2	H3	L	DNA NPT	DNM NPT	PACKING DIMENSIONS*			WEIGHT* PUMP UNIT lbs Kg	PACKING DIMENSIONS			WEIGHT DOCK lbs Kg
	inch mm	inch mm	inch mm	inch mm	inch mm	inch mm	inch mm	inch mm	inch mm	inch mm	inch mm	inch mm			PUMP UNIT				DOCK			
	L/A	L/B	H	L/A	L/B	H																
ESYBOX MAX 45/120	14.76	15.12	5.19	4.90	5.03	20.71	1.77	30.16	24.13	8.98	3.43	2.34	1"1/4 - 2"	1"1/4 - 2"	15.75	14.96	31.50	66	15.75	15.75	9.84	20
	375	384	131.8	124.5	127.7	526	45	766	613	228	87	59.5			400	380	800	30	400	400	250	9
ESYBOX MAX 60/120	14.76	15.12	5.19	4.90	5.03	20.71	1.77	30.16	24.13	8.98	3.43	2.34	1"1/4 - 2"	1"1/4 - 2"	15.75	14.96	31.50	66	15.75	15.75	9.84	20
	375	384	131.8	124.5	127.7	526	45	766	613	228	87	59.5			400	380	800	30	400	400	250	9
ESYBOX MAX 85/120	14.76	15.12	5.19	4.90	5.03	20.71	1.77	30.16	24.13	8.98	3.43	2.34	1"1/4 - 2"	1"1/4 - 2"	15.75	14.96	31.50	66	15.75	15.75	9.84	20
	375	384	131.8	124.5	127.7	526	45	766	613	228	87	59.5			400	380	800	30	400	400	250	9

* Weights and packaging dimensions refer to a pump unit

2 ESYBOX MAX - ELECTRONIC BOOSTER SET

Liquid temperature: +104°F (40°C) - Maximum ambient temperature: + 113°F (45°C)

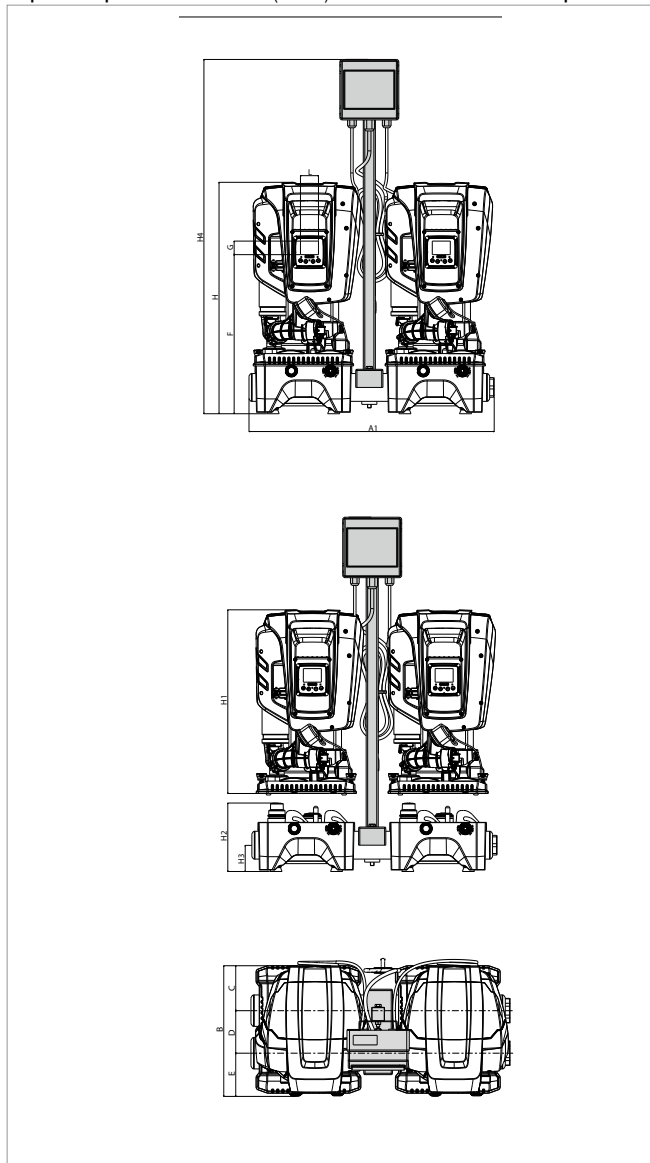

The performance curves are based on the kinematic viscosity values = 1 mm²/s and density equivalent to 1000 kg/m³. Curve tolerance according to ISO 9906.

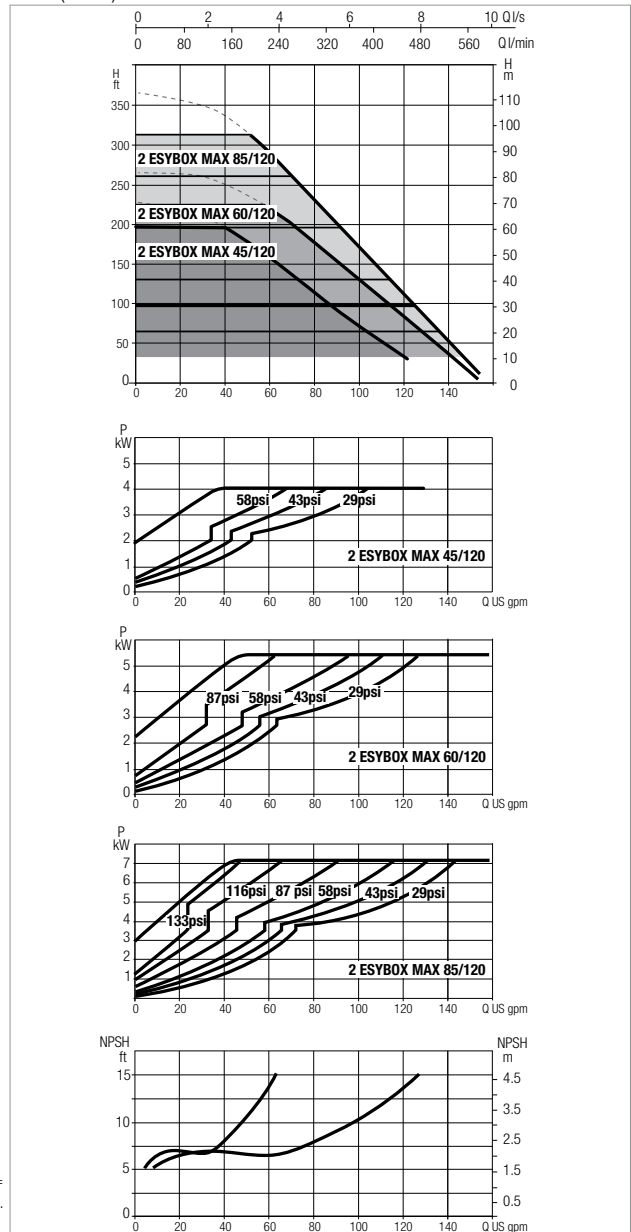

MODEL	ELECTRICAL DATA					
	N° IMPELLERS	POWER SUPPLY 50/60 Hz	P1 MAX		2x In A	SET POINT psi (bar)
			2x kW	2x HP		
2 ESYBOX MAX 45/120 M	3	1x208-240V ~	1.97	2.6	9.4	15 - 174 (1-12)
2 ESYBOX MAX 60/120 M	3	1x208-240V ~	2.68	3.6	12.5 - 11.5	15 - 174 (1-12)
2 ESYBOX MAX 60/120 T	3	3x380-480V ~	2.65	3.5	4.4	15 - 174 (1-12)
2 ESYBOX MAX 85/120 T	4	3x380-480 V ~	3.50	4.7	5.6	15 - 174 (1-12)

MODEL	A1	B	C	D	E	F	G	H	H1	H2	H3	H4**	L	DNA NPT	DNM NPT	PACKING DIMENSIONS*			WEIGHT* PUMP UNIT LBS Kg	PACKING DIMENSIONS DOCK			WEIGHT DOCK LBS Kg
																PUMP UNIT				DOCK			
																L/A	L/B	H	L/A	L/B	H		
2 ESYBOX MAX 45/120	31.93	15.12	5.19	4.90	5.03	20.71	1.77	30.16	24.13	8.98	3.43	46.14	2.34	2"	2"	15.75	14.96	31.50	64	35.43	15.75	9.84	40
	811	384	131.8	124.5	127.7	526	45	766	613	228	87	1172	59.5			400	380	800	29	900	400	250	18
2 ESYBOX MAX 60/120	31.93	15.12	5.19	4.90	5.03	20.71	1.77	30.16	24.13	8.98	3.43	46.14	2.34	2"	2"	15.75	14.96	31.50	64	35.43	15.75	9.84	40
	811	384	131.8	124.5	127.7	526	45	766	613	228	87	1172	59.5			400	380	800	29	900	400	250	18
2 ESYBOX MAX 85/120	31.93	15.12	5.19	4.90	5.03	20.71	1.77	30.16	24.13	8.98	3.43	46.14	2.34	2"	2"	15.75	14.96	31.50	64	35.43	15.75	9.84	40
	811	384	131.8	124.5	127.7	526	45	766	613	228	87	1172	59.5			400	380	800	29	900	400	250	18

* Weights and packaging dimensions refer to a pump unit

3 ESYBOX MAX - ELECTRONIC BOOSTER SET

Liquid temperature: +104°F (40°C) - Maximum ambient temperature: + 113°F (45°C)

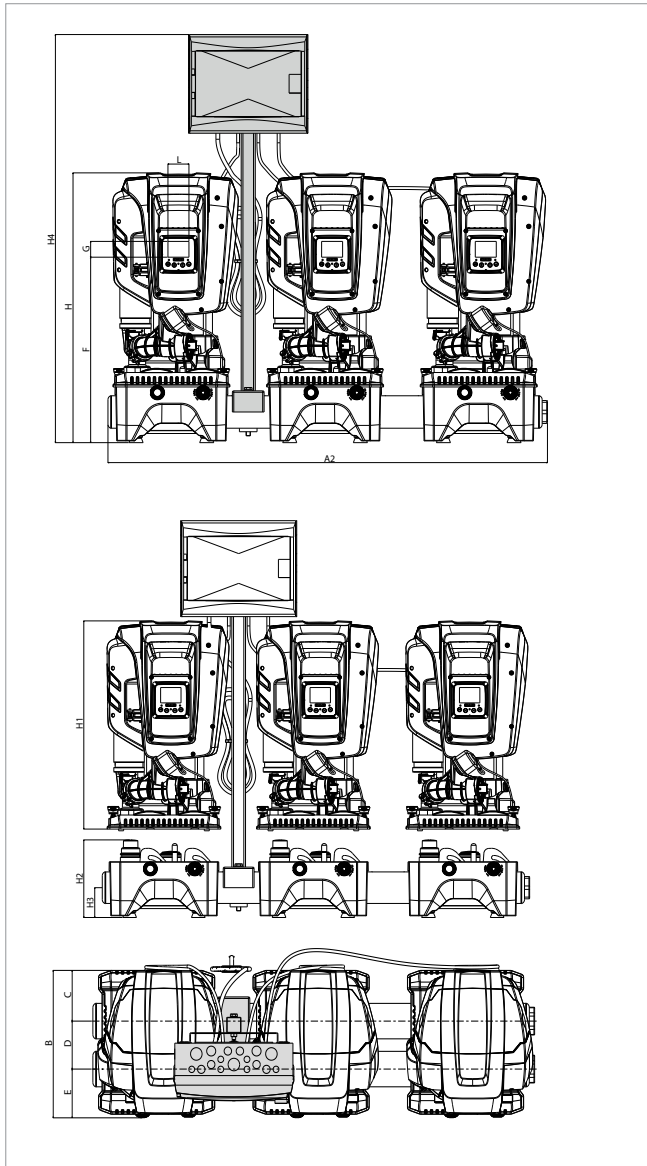

The performance curves are based on the kinematic viscosity values = 1 mm²/s and density equivalent to 1000 kg/m³. Curve tolerance according to ISO 9906.

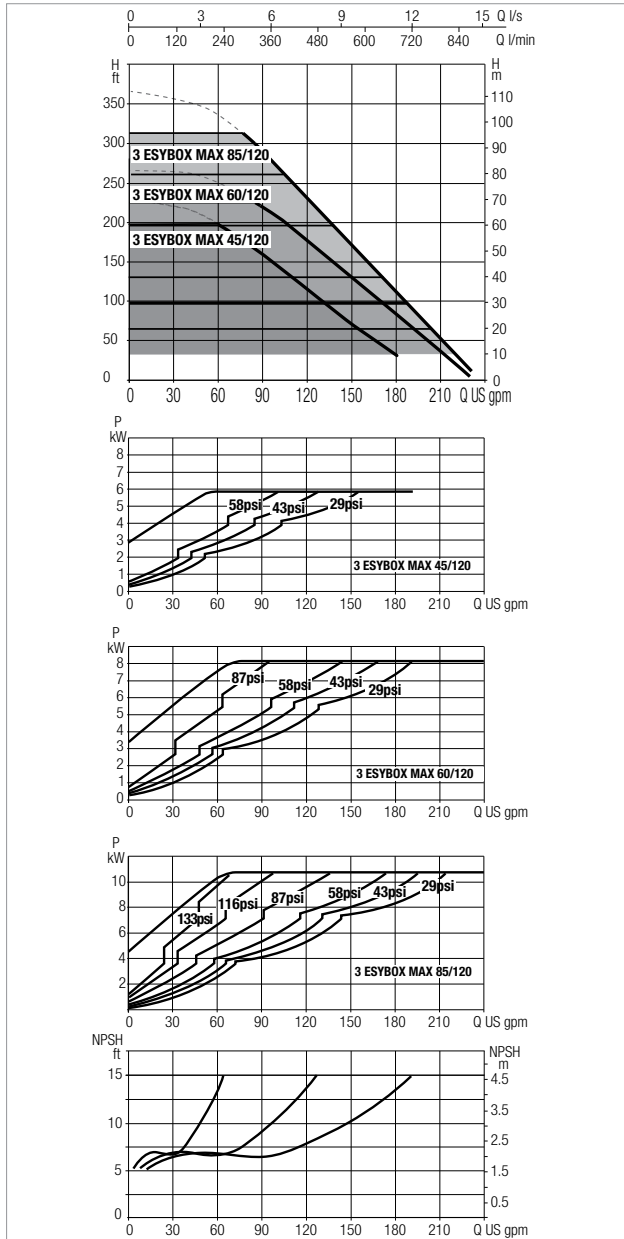

MODEL	N° IMPELLERS	POWER SUPPLY 50/60 Hz	ELECTRICAL DATA			
			P1 MAX		3x In A	SET POINT psi (bar)
			3x kW	3x HP		
3 ESYBOX MAX 45/120 M	3	1x208-240 V~	1.97	2.6	9.4	15 - 174 (1-12)
3 ESYBOX MAX 60/120 M	3	1x208-240 V~	2.68	3.6	12.5 - 11.5	15 - 174 (1-12)
3 ESYBOX MAX 60/120 T	3	3x380-480 V~	2.65	3.5	4.4	15 - 174 (1-12)
3 ESYBOX MAX 85/120 T	4	3x380-480 V~	3.50	4.7	5.6	15 - 174 (1-12)



MODEL	A1	B	C	D	E	F	G	H	H1	H2	H3	H4**	L	DNA NPT	DNM NPT	PACKING DIMENSIONS*			WEIGHT* PUMP UNIT LBS Kg	PACKING DIMENSIONS DOCK			WEIGHT DOCK LBS Kg
	inch mm	inch mm	inch mm	inch mm	inch mm	inch mm	inch mm	inch mm	inch mm	inch mm	inch mm	inch mm	PUMP UNIT			L/A	L/B	H					
	L/A	L/B	H																				
3 ESYBOX MAX45/120	49.21	15.12	5.19	4.90	5.03	20.71	1.77	30.16	24.13	8.98	3.43	45.59	2.34	2"	2"	15.75	14.96	31.50	64	49.21	15.75	9.84	60
	1250	384	131.8	124.5	127.7	526	45	766	613	228	87	1158	59.5			400	380	800	29	1250	400	250	27
3 ESYBOX MAX 60/120	49.21	15.12	5.19	4.90	5.03	20.71	1.77	30.16	24.13	8.98	3.43	45.59	2.34	2"	2"	15.75	14.96	31.50	64	49.21	15.75	9.84	60
	1250	384	131.8	124.5	127.7	526	45	766	613	228	87	1158	59.5			400	380	800	29	1250	400	250	27
3 ESYBOX MAX 85/120	49.21	15.12	5.19	4.90	5.03	20.71	1.77	30.16	24.13	8.98	3.43	45.59	2.34	2"	2"	15.75	14.96	31.50	64	49.21	15.75	9.84	60
	1250	384	131.8	124.5	127.7	526	45	766	613	228	87	1158	59.5			400	380	800	29	1250	400	250	27

* Weights and packaging dimensions refer to a pump unit

ACCESSORIES

ESYBOX MAX

	DESCRIPTION	MODEL	ESYBOX MAX	2 ESYBOX MAX	3 ESYBOX MAX	4 ESYBOX MAX
	<h3>ESY I/O</h3> <p>The electronic expansion module allows Esybox Max to interface with the external input/output devices (eg: float switch, pressure switch, remote alarm) and with the BMS world (Building Management System).</p>		•	•	•	•

	DESCRIPTION
 <p>9.1 x 15 x 15 in</p>	<h3>ESYDOCK MAX</h3> <p>Esydock Max is the mounting base to assemble the pumping system at the installation site quickly and conveniently. It connects to the system with four different hydraulic configuration modes and with its anti-vibration feet it maintains a high level of quietness.</p>
 <p>9.1 x 31.9 15 in</p>	<h3>2 ESYDOCK MAX</h3> <p>It is the mounting base used to create two-pump units. The exceptional performance offered by the combined operation of two Esybox Max units is combined with a 50% reduction in dimensions compared to conventional systems with the same performance.</p>
 <p>9.1 x 49.2 x 15 in</p>	<h3>3 ESYDOCK MAX</h3> <p>Mounting base for three-pump units. The modular concept is realised in an absolutely flexible, high-performance system. Maximum results with minimum space requirements and extremely easy and user-friendly installation.</p>



EASY TO MOVE & INSTALL

Keeping it flexible, we use the On-Site Assembly concept. So if you have difficulties getting to the pumps location, due to narrow stairways and corridors etc., you can choose to assemble your booster on-site which will only require moving smaller lighter boxes into the location then carry out our quick assembly steps.











AS QUICK AS A "CLICK"

Install Esydock into your pipework system and simply "plug" your pumps in. A final quick set up via the digital DConnect app completes your installation project.

ESYBOX MAX

ELECTRONIC BOOSTER SET

CONFIGURATION TABLE

GROUP TOTAL (PUMP UNIT + DOCK)	PUMP UNIT			DOCK		
	MODEL	CODE	Q.TY PUMP UNIT	MODEL	CODE	Q.TY DOCK
 esybox max	ESYBOX MAX 45/120 M	60217370	1 PUMP UNIT 	ESYDOCK MAX	60199045	1 SINGLE DOCK 
	ESYBOX MAX 60/120 M	60199039				
	ESYBOX MAX 60/120 T	60199035				
	ESYBOX MAX 85/120 T	60195100				
 2 esybox max *	ESYBOX MAX 45/120 M	60217370	2 PUMP UNITS 	2 ESYDOCK MAX	60199055	1 TWIN DOCK 
	ESYBOX MAX 60/120 M	60199039				
	ESYBOX MAX 60/120 T	60199035				
	ESYBOX MAX 85/120 T	60195100				
 3 esybox max	ESYBOX MAX 45/120 M	60217370	3 PUMP UNITS 	3 ESYDOCK MAX	60199056	1 TRIPLE DOCK 
	ESYBOX MAX 60/120 M	60199039				
	ESYBOX MAX 60/120 T	60199035				
	ESYBOX MAX 85/120 T	60195100				

* With 2 Units of 2 Esybox Max you obtain the 4 pump units group.

DIMENSIONS
(PUMP UNIT + DOCK)
30.3 x 15 x 15 in

SOUND
PRESSURE**
63 db(A)



DIMENSIONS (ONLY DOCK)
9.1 x 15 x 15 in

esybox max

DIMENSIONS
(PUMP UNIT + DOCK)
30.3 x 31.9 x 15 in



DIMENSIONS (ONLY DOCK)
9.1 x 31.9 x 15 in

2 esybox max *

DIMENSIONS
(PUMP UNIT + DOCK)
30.3 x 49.2 x 15 in



DIMENSIONS (ONLY DOCK)
9.1 x 49.2 x 15 in

3 esybox max *

* To configure the 2/3/4 Esybox Max version you can combine the control panel and the pillar kit to facilitate the electrical sectioning of the pumps.

** Sound pressure measured at 3 ft distance in free field. 13.2GPM and 87 psi.

DNA

P U M P S S E L E C T O R

On-line selection tool



DAB PUMPS LTD.

6 Gilbert Court
Newcomen Way
Severalls Business Park
Colchester
Essex
CO4 9WN - UK
salesuk@dwgroup.com
Tel. +44 0333 777 5010



DAB PUMPS IBERICA S.L.

Calle Verano 18-20-22
28850 - Torrejón de Ardoz - Madrid
Spain
Info.spain@dwgroup.com
Tel. +34 91 6569545
Fax: + 34 91 6569676



DAB PUMPS SOUTH AFRICA (PTY) LTD

Twenty One industrial Estate,
16 Purlin Street, Unit B, Warehouse 4
Olifantsfontein -1666 - South Africa
info.sa@dwgroup.com
Tel. +27 12 361 3997



DAB PUMPS BV

'tHofveld 6 C1
1702 Groot Bijgaarden - Belgium
info.belgium@dwgroup.com
Tel. +32 2 4668353



DAB PUMPS HUNGARY KFT.

H-8800
Nagykanizsa, Buda Ernő u.5
Hungary
Tel. +36 93501700



DAB PUMPS (QINGDAO) CO. LTD.

No.40 Kaituo Road, Qingdao Economic & Technological
Development Zone
Qingdao City, Shandong Province - China
PC: 266500
sales.cn@dwgroup.com
Tel. +86 400 186 8280
Fax +86 53286812210



DAB PUMPS POLAND Sp. z o.o.

Ul. Janka Muzykanta 60
02-188 Warszawa - Poland
polska@dabpumps.com.pl



DAB PUMPS DE MÉXICO, S.A. DE C.V.

Av Amsterdam 101 Local 4
Col. Hipódromo Condesa,
Del. Cuauhtémoc CP 06170
Ciudad de México
Tel. +52 55 6719 0493



DAB PUMPS B.V.

Albert Einsteinweg, 4
5151 DL Drunen - Nederland
info.netherlands@dwgroup.com
Tel. +31 416 387280
Fax +31 416 387299



OOO DAB PUMPS

Novgorodskaya str. 1, block G
office 308, 127247, Moscow - Russia
info.russia@dwgroup.com
Tel. +7 495 122 0035
Fax +7 495 122 0036



DAB PUMPS OCEANIA PTY LTD

426 South Gippsland Hwy,
Dandenong South VIC 3175 - Australia
info.oceania@dwgroup.com
Tel. +61 1300 373 677



DAB PUMPS GMBH

Am Nordpark 3
D - 41069 Mönchengladbach - Germany
info.germany@dwgroup.com
Tel. +49 2161 47388-0
Fax +49 2161 47388-36



DAB PUMPS INC.

3226 Benchmark Drive
Ladson, SC 29456 - USA
info.usa@dwgroup.com
Tel. 1- 843-797-5002
Fax 1-843-797-3366



PT DAB PUMPS INDONESIA

Satrio Tower Iantai 26
unit C-D, Jl. Prof. Dr. Satrio Kav. C4,
Kel. Kuningan Timur, Kec. Setiabudi, Kota Adm.
Jakarta Selatan, Prov. DKI Jakarta. - Indonesia
Tel. +62 2129222850